

frikool



AIR DIFFUSION PRODUCTS

OUR COMPANY

Factory Tour

The name Ventech is synonymous with high quality products in the commercial air conditioning terminal industry.

Beginning in 2006, Ventech continues to be a leading supplier of central air conditioning terminal products in the international market.

Ventech research and development plus a strict quality control program have been fundamental to our growth, success and reputation. Ventech units are manufactured in accordance with strict quality control standards and developed for international conditions.

Range: Ventech's modern factory manufacture full range of air grilles and diffusers, air louvers, volume control dampers, fire dampers. And Ventech is working continuously to improve its product range and efficiency.

Specialized Solutions: Ventech will design and manufacture products to suit the application and building design. Our mechanical engineers are ready for OEM requirements also.

Ventech maintains a dedicated engineering and sales support staff waiting to assist you with technical and product information, and provide valuable air solutions for your project.





SCD-VA

(standard)



SCD-VB

(X Type)



SCD-VC

(Ceiling replacement type)

- * The directions of discharge air can be selected to meet the requirements of room with 1 to 4 way.
- * Supply air can be oriented to vertically be blades of 1,2,3,4 directions.
- * They can be used both for supply and return applications.
- * Depending on architectural demands the face can be square or rectangular.
- * They are suitable for using in rooms with heights up to 4m.
- * Material: They can be made of extruded aluminum profiles, or aluminum sheet.
- * Accessories: Damper, Plenum box.
- * Mount: by screws, by clips.
- * Finishing: White powder coating Ral9016, Ral9010, or customized color. Anodized.

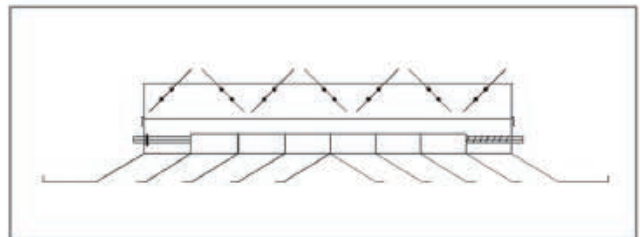
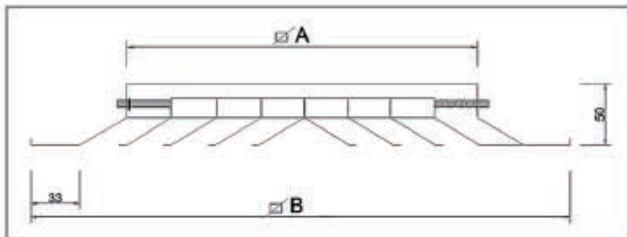

Selection Tables

Standard sizes AxA(mm)	BxB(mm)	Effective area(m ²)	Air volume(m ³ /h)	Throw Max. (m)
150x150	295x295	0.014	119	0.90
225x225	370x370	0.028	240	1.40
300x300	445x445	0.049	400	1.70
375x375	520x520	0.069	600	2.00
450x450	595x595	0.097	840	2.40
525x525	670x670	0.130	1120	2.55
600x600	745x745	0.169	1460	2.70

Data were chosen when the air velocity is 2.4m/s and the velocity at throw distance is 0.5m/s

Types

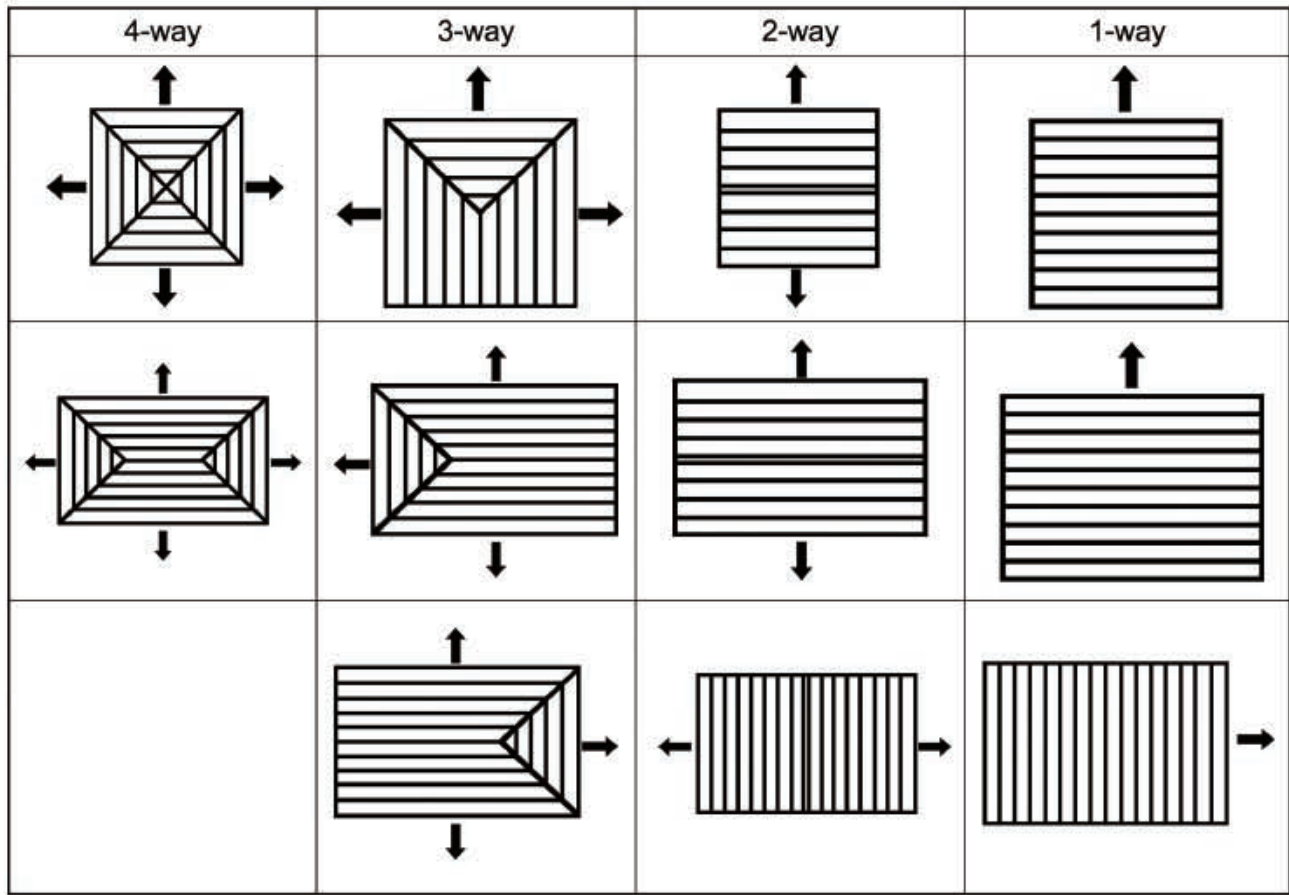

Mounting

1. Screw mounting
2. Lay-on mounting

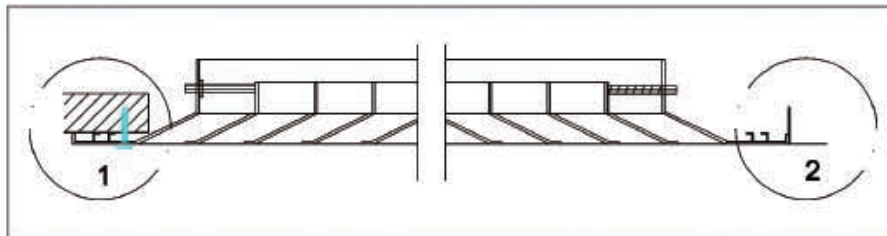

3. Clip-in mounting

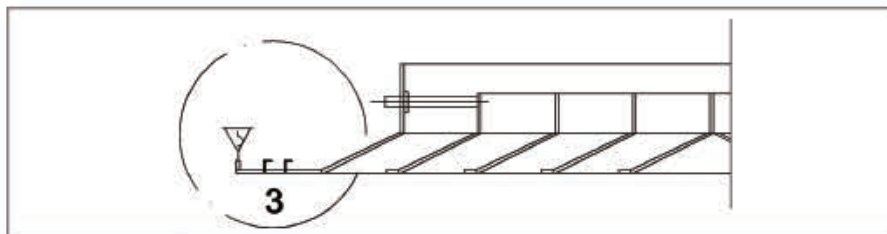

Plenum box / Adaptor

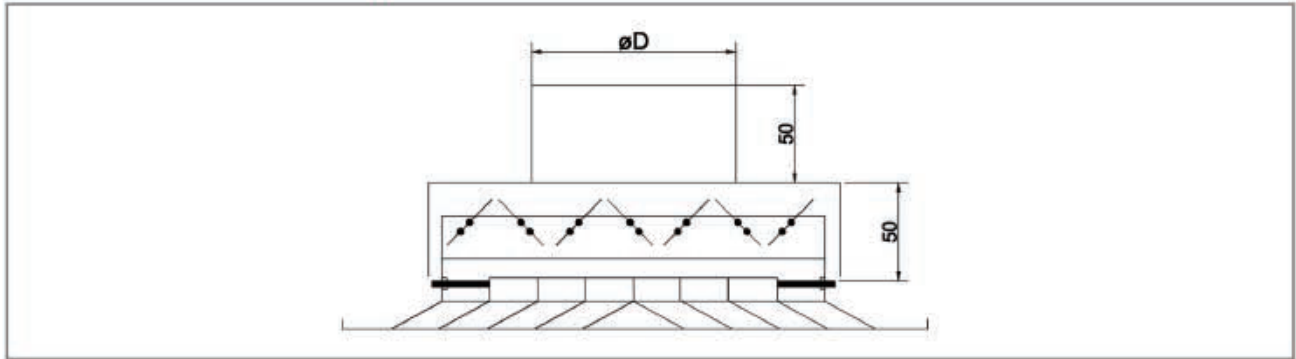

D=95, 145, 195, 245, 295, 345

Technical data

SCD-VA / VB		AIR VOLUME(m ³ /h)													
Size (mm)	Effective Area(m ²)		100	200	300	400	500	600	700	800	900	1000	2000	3000	4000
150x150	0.0138	Vk(m/s)	2	4	6.4	-	-	-	-	-	-	-	-	-	-
		Pt(pa)	3.4	9.6	24.7	-	-	-	-	-	-	-	-	-	-
		Lt(m)	-	1.6	2.4	-	-	-	-	-	-	-	-	-	-
		NR	-	23	33	-	-	-	-	-	-	-	-	-	-
225x225	0.0277	Vk(m/s)	-	2	2.9	4	4.8	-	-	-	-	-	-	-	-
		Pt(pa)	-	2.4	4.7	9.6	13.9	-	-	-	-	-	-	-	-
		Lt(m)	-	1.1	1.7	2.3	2.5	-	-	-	-	-	-	-	-
		NR	-	-	20	25	30	-	-	-	-	-	-	-	-
300x300	0.0486	Vk(m/s)	-	-	1.8	2.4	2.8	3.5	4	4.7	5.4	6	-	-	-
		Pt(pa)	-	-	2	3.5	4.7	7.5	9.6	13	17.6	21.7	-	-	-
		Lt(m)	-	-	1.3	1.7	2	2.45	2.5	3.1	3.4	4	-	-	-
		NR	-	-	-	16	21	25	28	31	34	36	-	-	-
375x375	0.0694	Vk(m/s)	-	-	-	1.6	2	2.4	2.7	3	3.4	4	-	-	-
		Pt(pa)	-	-	-	1.5	2.4	3.5	4.7	5.4	7	9.6	-	-	-
		Lt(m)	-	-	-	1.5	1.7	2.1	2.4	2.5	2.7	3.2	-	-	-
		NR	-	-	-	-	15	18	22	24	26	37	-	-	-
450x450	0.0972	Vk(m/s)	-	-	-	-	-	1.7	2	2.3	2.1	2.7	5.5	-	-
		Pt(pa)	-	-	-	-	-	1.5	2.4	3.2	3.5	4.7	19	-	-
		Lt(m)	-	-	-	-	-	1.7	2.3	2.3	2.5	2.6	5	-	-
		NR	-	-	-	-	-	-	16	18	21	24	37	-	-
525x525	0.1296	Vk(m/s)	-	-	-	-	-	-	-	1.8	2	2.2	4.2	6.4	-
		Pt(pa)	-	-	-	-	-	-	-	2	2.4	2.9	10.6	24.7	-
		Lt(m)	-	-	-	-	-	-	-	2	2.3	2.5	4.3	7	-
		NR	-	-	-	-	-	-	-	14	16	18	33	42	-
600x600	0.1692	Vk(m/s)	-	-	-	-	-	-	-	-	-	1.6	3	4.7	-
		Pt(pa)	-	-	-	-	-	-	-	-	-	1.5	5.4	13	-
		Lt(m)	-	-	-	-	-	-	-	-	-	2.3	4	6.5	-
		NR	-	-	-	-	-	-	-	-	-	15	28	36	-

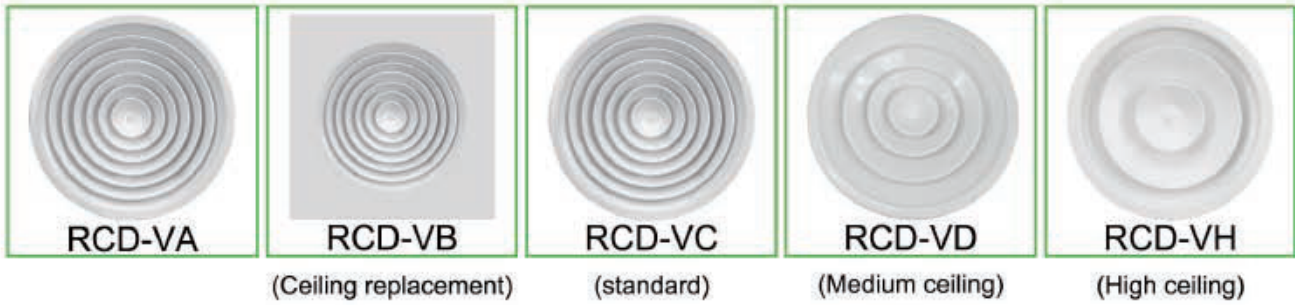

- * The circular design guarantees an uniform radial discharge in supply air applications.
- * They can be used both for supply and return applications.
- * They are suitable for using in rooms with heights up to 4m(A,B,C designs), 6m(D design), 8M(H design)
- * Material: They are made of aluminum sheet.
- * Accessories: Damper (butterfly damper in plastic or steel manual control; radial-shape damper screw control.)
- * Mounting: Screw type.
- * Finishing: White powder coating Ra19016, Ra19010, or customized color. Anodized.

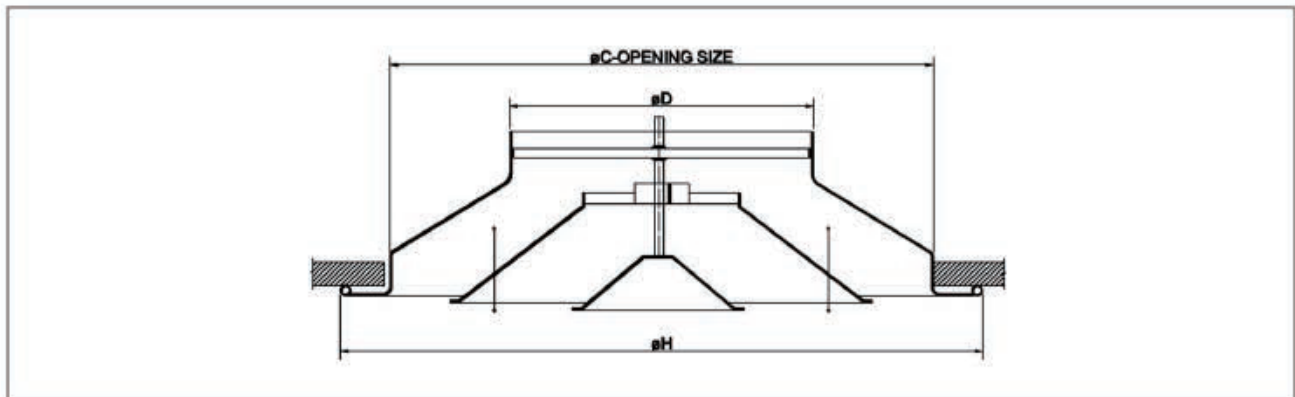
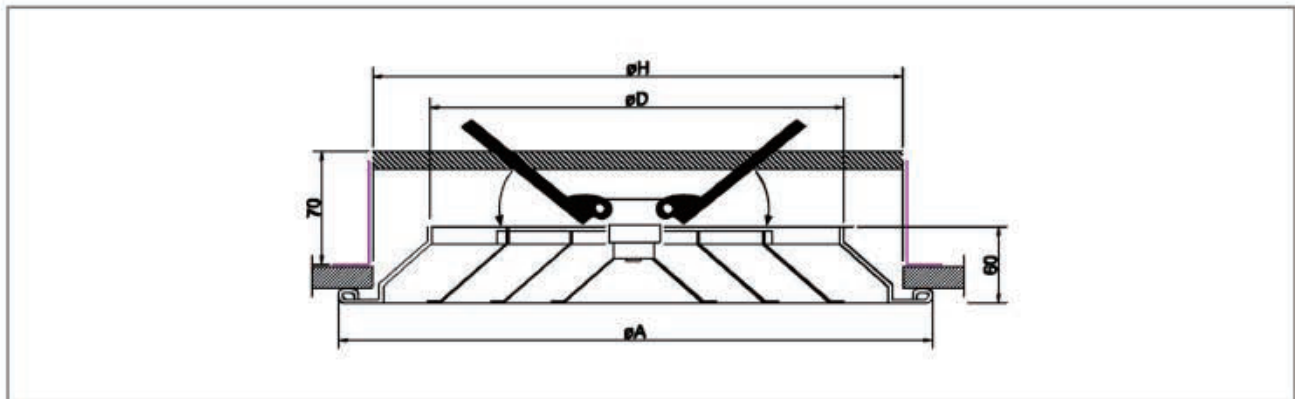

Selection Tables

Size(mm)	RCD-VA, VC ØD(mm)	RCD-VA, VC ØA(mm)	RCD-VB ØA(mm)	Air volume (m3/h)	Throw Max. (m)
150	145	250	595x595	135	0.8
200	195	300	595x595	240	1.3
250	245	350	595x595	360	1.55
300	295	400	595x595	500	1.8
350	345	450	595x595	666	2.2
400	395	500	595x595	810	2.4
450	445	550	595x595	1050	2.7
500	495	600	595x595	1215	2.9

Size(mm)	RCD-VD ØD(mm)	RCD-VD ØA(mm)	Air volume (m3/h)	Throw Max. (m)
150	145	300	148	0.9
200	195	395	260	1.5
250	245	445	395	1.8
300	295	495	560	2.3
350	345	545	750	2.8

Size(mm)	RCD-VH ØD(mm)	RCD-VH ØA(mm)	Air volume (m3/h)	Throw Max. (m)
150	145	325	160	1.4
200	195	430	285	2.3
250	245	530	445	2.7
300	295	640	640	3.1
350	345	720	865	3.6

Data were chosen when the air velocity is 2.5m/s and the velocity at throw distance is 0.25m/s.



RCD-VA, VB, VC			AIR VOLUME(m ³ /h)													
Size (mm)	Effective Area(m ²)		150	200	300	400	500	600	700	800	900	1000	1400	2000	2500	
150	0.011	Vk(m/s)	3.8	5.2	7.8	-	-	-	-	-	-	-	-	-	-	-
		Pt(pa)	15	24	65	-	-	-	-	-	-	-	-	-	-	-
		Lt(m)	2.2	2.8	4.5	-	-	-	-	-	-	-	-	-	-	-
		NR	-	28	48	-	-	-	-	-	-	-	-	-	-	-
200	0.020	Vk(m/s)	2.3	2.8	4.5	6.0	7.4	-	-	-	-	-	-	-	-	-
		Pt(pa)	5.4	7.9	20	30	60	-	-	-	-	-	-	-	-	-
		Lt(m)	1.6	2.2	3.4	4.5	4.5	-	-	-	-	-	-	-	-	-
		NR	-	-	27	36	48	-	-	-	-	-	-	-	-	-
250	0.031	Vk(m/s)	-	-	2.8	3.8	4.6	5.5	6.5	7.5	-	-	-	-	-	-
		Pt(pa)	-	-	7.9	16	21	26	41	62	-	-	-	-	-	-
		Lt(m)	-	-	2.7	3.1	4.5	5.4	6.2	4.5	-	-	-	-	-	-
		NR	-	-	-	-	30	36	42	48	-	-	-	-	-	-
300	0.046	Vk(m/s)	-	-	-	2.5	3.1	3.7	4.3	5.0	5.5	6.2	-	-	-	-
		Pt(pa)	-	-	-	6.5	9	15	19	22	26	34	-	-	-	-
		Lt(m)	-	-	-	2.8	3.6	4.7	5.3	6	7	6.2	-	-	-	-
		NR	-	-	-	-	-	25	30	35	38	42	-	-	-	-
350	0.055	Vk(m/s)	-	-	-	2.0	2.5	3.0	3.5	4.0	4.5	5.0	7.0	-	-	-
		Pt(pa)	-	-	-	4.2	6.5	8	13	17	20	22	51	-	-	-
		Lt(m)	-	-	-	2.6	3.2	3.7	4.7	5.2	6	7	9.8	-	-	-
		NR	-	-	-	-	-	-	24	27	33	36	47	-	-	-
400	0.070	Vk(m/s)	-	-	-	-	2.0	2.4	2.8	3.3	3.6	4.0	5.5	-	-	-
		Pt(pa)	-	-	-	-	4.2	6.1	7.9	11	14	17	26	-	-	-
		Lt(m)	-	-	-	-	2.8	3.4	4.2	4.7	5.2	6	9	-	-	-
		NR	-	-	-	-	-	-	-	23	26	30	42	-	-	-
450	0.089	Vk(m/s)	-	-	-	-	-	-	2.3	-	2.8	3.1	4.2	6.0	-	-
		Pt(pa)	-	-	-	-	-	-	5.4	2.4	7.9	9	18	30	7.8	
		Lt(m)	-	-	-	-	-	-	3.4	6.1	4.6	5.1	8	10.5	65	
		NR	-	-	-	-	-	-	-	4.2	-	23	34	46	13	
500	0.108	Vk(m/s)	-	-	-	-	-	-	-	2.0	-	2.5	3.6	5.0	6.2	
		Pt(pa)	-	-	-	-	-	-	-	4.2	2.3	6.5	14	22	34	
		Lt(m)	-	-	-	-	-	-	-	3.6	5.2	4.6	7	10	12	
		NR	-	-	-	-	-	-	-	-	4.2	-	28	41	48	

RCD-VD			AIR VOLUME(m3/h)													
Size (mm)	Effective Area(m2)		200	300	400	500	600	700	800	900	1000	1400	2000	2500	3000	
150	0.011	Vk(m/s)	3.7	5.8	7.8	-	-	-	-	-	-	-	-	-	-	-
		Pt(pa)	15	36	63	-	-	-	-	-	-	-	-	-	-	-
		Lt(m)	0.7	1.15	1.4	-	-	-	-	-	-	-	-	-	-	-
		NR	25	38	48	-	-	-	-	-	-	-	-	-	-	-
200	0.020	Vk(m/s)	2.1	3.2	4.2	5.2	6.1	7.3	-	-	-	-	-	-	-	
		Pt(pa)	4.7	10	19	29	40	56	-	-	-	-	-	-	-	-
		Lt(m)	-	0.8	1.15	1.35	1.7	1.9	-	-	-	-	-	-	-	-
		NR	-	22	31	38	45	52	-	-	-	-	-	-	-	-
250	0.031	Vk(m/s)	-	2.2	2.8	3.5	4.2	4.9	5.6	6.2	7.2	-	-	-	-	
		Pt(pa)	-	5.1	7.9	13	19	26	25	43	53	-	-	-	-	
		Lt(m)	-	0.65	0.85	1.15	1.4	1.6	1.8	2.1	2.4	-	-	-	-	
		NR	-	-	21	27	33	38	44	47	50	-	-	-	-	
300	0.046	Vk(m/s)	-	-	2.0	2.5	3.0	3.5	4.0	4.5	5.0	7.0	-	-	-	
		Pt(pa)	-	-	4.2	6.5	9	13	17	22	26	51	-	-	-	
		Lt(m)	-	-	0.72	0.92	1.1	1.35	1.5	1.7	1.8	2.7	-	-	-	
		NR	-	-	-	-	24	29	34	37	42	-	-	-	-	
350	0.055	Vk(m/s)	-	-	-	-	2.2	2.6	3.0	3.4	3.7	5.2	-	-	-	
		Pt(pa)	-	-	-	-	5.1	7.3	9	12	15	29	7.5	-	-	
		Lt(m)	-	-	-	-	0.9	0.9	1.4	1.5	1.6	2.4	5.9	-	-	
		NR	-	-	-	-	-	-	26	30	37	45	3.5	-	-	

RCD-VH			AIR VOLUME(m3/h)												
Size (mm)	Effective Area(m2)		200	300	400	500	600	700	800	900	1000	1400	2000	2500	3000
150	0.011	Vk(m/s)	3.3	4.6	6.3	-	-	-	-	-	-	-	-	-	-
		Pt(pa)	30	49	85	-	-	-	-	-	-	-	-	-	-
		Lt(m)	3.4	4.5	6.0	-	-	-	-	-	-	-	-	-	-
		NR	30	41	52	-	-	-	-	-	-	-	-	-	-
200	0.020	Vk(m/s)	-	2.6	3.5	4.4	5.6	-	-	-	-	-	-	-	
		Pt(pa)	-	17	31	49	68	-	-	-	-	-	-	-	
		Lt(m)	-	1.8	2.9	3.8	4.7	-	-	-	-	-	-	-	
		NR	-	22	31	45	67	-	-	-	-	-	-	-	
250	0.031	Vk(m/s)	-	-	2.3	2.9	3.4	4.0	4.5	5.1	5.9	-	-	-	
		Pt(pa)	-	-	13	20	25	31	37	46	64	-	-	-	
		Lt(m)	-	-	1.3	2.1	2.6	3.1	3.6	3.9	4.7	-	-	-	
		NR	-	-	14	23	27	31	36	40	46	-	-	-	
300	0.046	Vk(m/s)	-	-	-	2.0	2.4	2.6	2.8	3.5	4.0	4.8	-	-	
		Pt(pa)	-	-	-	11	14	16	18	25	34	68	-	-	
		Lt(m)	-	-	-	0.8	1.4	1.7	2.1	2.3	2.8	4.2	-	-	
		NR	-	-	-	15	20	24	27	30	35	45	-	-	
350	0.055	Vk(m/s)	-	-	-	-	-	2.0	2.3	2.7	3.1	4.0	5.9	-	
		Pt(pa)	-	-	-	-	-	11	14	18	22	38	80	-	
		Lt(m)	-	-	-	-	-	0.8	0.9	1.1	1.7	2.9	3.8	-	
		NR	-	-	-	-	-	16	2	24	27	35	48	-	



- * Jet nozzles are developed for large and high area, such as airports, shopping centers, show centers, theaters etc.
- * It ensures a long throw(25m) at high outlet velocities.
- * The ball can be oriented 30° angle.
- * They are used for cooling or heating with the characteristic of orientation.
- * Rotated by manual or motor control.
- * Material: They are made of aluminum sheet.
- * Accessories: Damper (butterfly damper in plastic or steel manual control; radial-shape damper screw control.)
- * Mounting: Ceiling or wall mounting by screws, or collected into a circular duct.
- * Finishing: White powder coating Ral9016, Ral9010, or customized color.

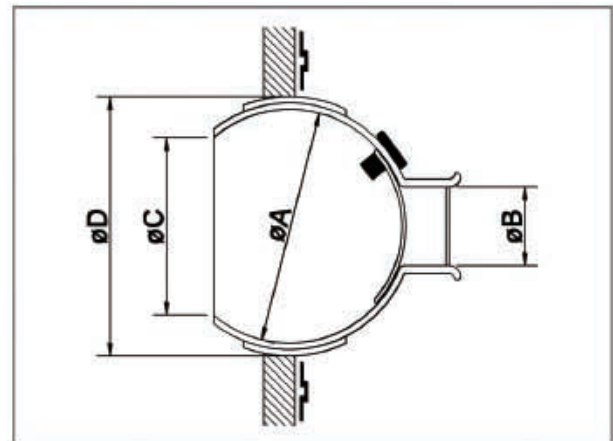
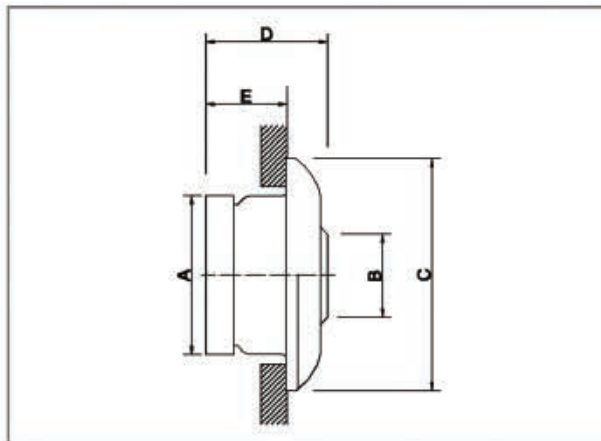

JD-VA size(mm)	A	B	C	D	E
125	120	61	172	96	72
150	145	75	200	113	83
160	155	75	200	113	83
200	195	105	265	142	107
250	245	128	314	179	135
315	310	165	390	230	174
350	345	185	433	251	186
400	395	210	495	285	218
450	445	235	559	316	235
500	495	256	618	350	259
630	625	323	779	440	335

JD-VB size(mm)	A	B	C	D
160	145	80	115	160
200	195	100	160	220
250	245	125	215	260
315	310	162	255	320
400	395	200	345	410

JD-VA size(mm)	Suitable round duct diameter						
	200	250	315	500	630	800	1000
125							
150	•	•					
160			•	•	•	•	
200			•	•	•	•	
250				•	•	•	
315				•	•	•	
350					•	•	
400					•	•	
450						•	
500						•	•
630							•

JD-VB size(mm)	Suitable round duct diameter			
	315	500	630	800
160	•	•	•	•
200		•	•	•
250		•	•	•
315		•	•	•
400			•	•

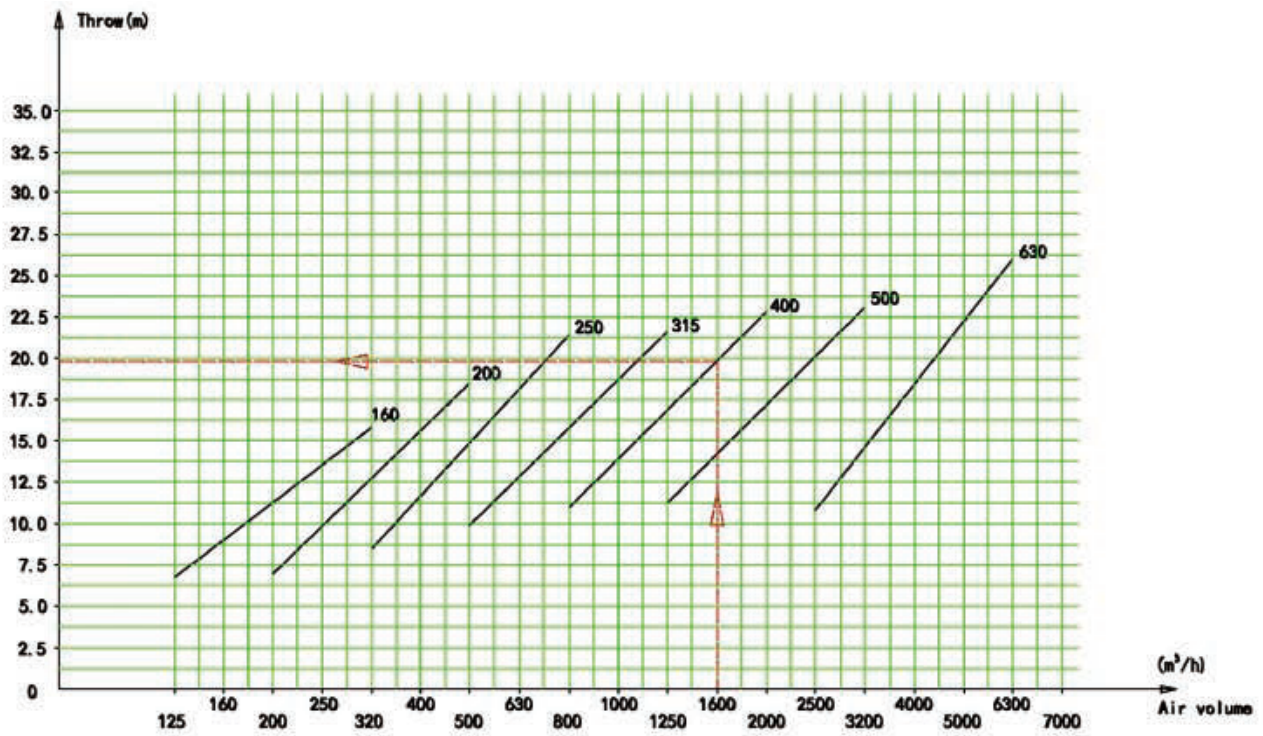

Curve of air volume and throw for JD-VA Series($V_x=0.5\text{m/s}$)

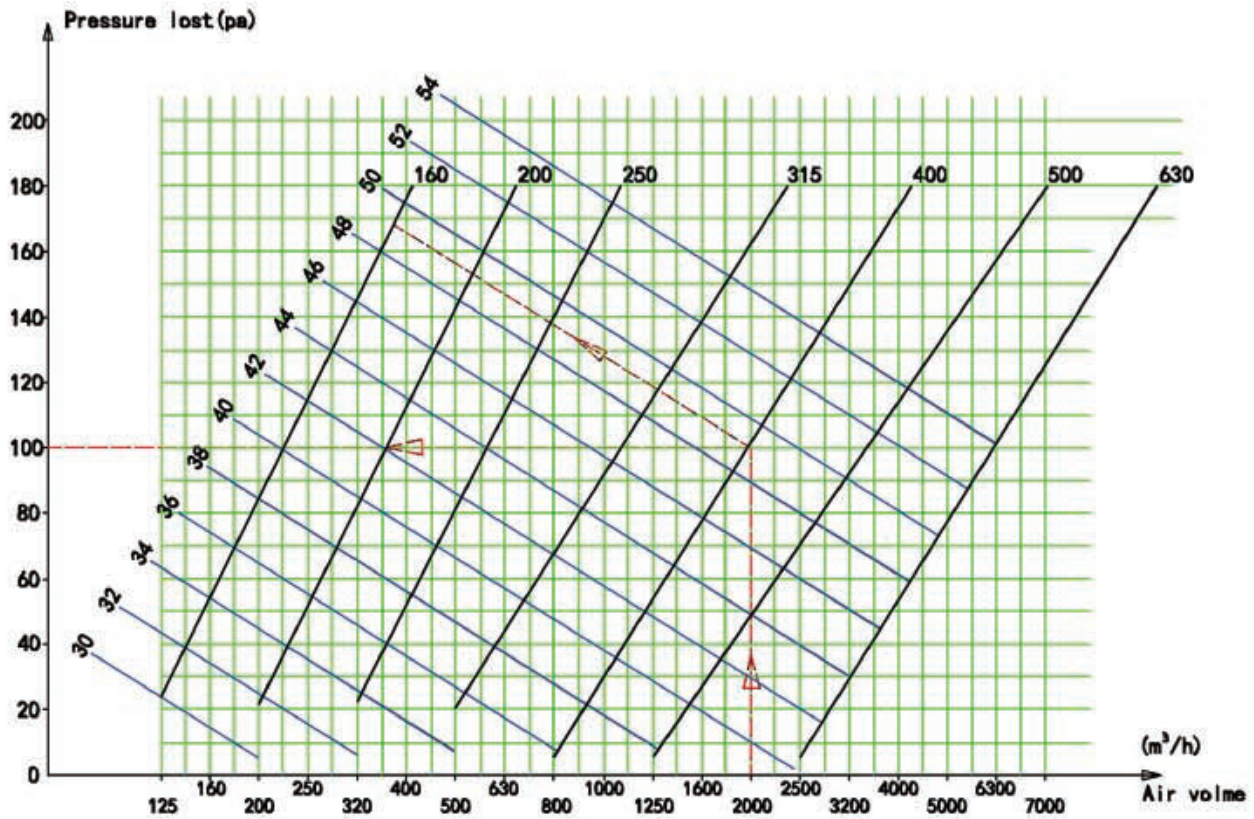

Curve of air volume ,pressure lost and noise for JD-VA Series($V_x=0.5\text{m/s}$)

Size(mm)	Effective area(m ²)	Air volume(m ³ /h)	Pressure lost (Pa)	Noise dB(A)	Throw (m)
160	0.005	100	18.5	26	10.8
		125	22.8	30	13.5
		160	56	34	17.4
		200	82	39	22.2
		250	116	43	27.3
200	0.009	160	10	30	12.7
		200	21	33	16
		250	54	38	20
		320	82	41	25.7
		400	116	45	32.2
250	0.0145	250	11	29	12.9
		320	22	34	16.9
		400	55	39	25.2
		500	81	42	31.5
		630	116	46	37.5
315	0.023	400	12.8	26	16
		500	21	34	20
		630	46	38	25
		800	68	42	30.2
		1000	94	46	37
400	0.0415	630	8	32	17.6
		800	17	36	22.2
		1000	31	39	28.4
		1250	58	43	34
		1600	80	46	40
500	0.0642	1000	5	30	18.3
		1250	12	36	22.8
		1600	28.8	41	28.9
		2000	51	44	34.8
		2500	70	50	41.2
630	0.127	2000	6	36	17.5
		2500	12.5	41	21.8
		3200	29.4	43	27.6
		4000	52	46	35.4
		5000	78	49	44.3

Data were chosen when the air velocity is 2.5m/s and the velocity at throw distance is 0.25m/s.

Size(mm)	Effective area(m ²)	Air volume(m ³ /h)	Pressure lost (Pa)	Noise dB(A)	Throw (m)
160	0.0033	100	19	26	10.8
		125	23	30	13.5
		160	58	34	17.4
		200	85	39	22.2
		250	119	43	27.3
200	0.0079	160	12	30	12.7
		200	23	33	16
		250	56	38	20
		320	84	41	25.7
		400	117	45	32.2
250	0.0122	250	11	29	12.9
		320	22	34	16.9
		400	55	39	25.2
		500	81	42	31.5
		630	116	46	37.5
315	0.0214	400	12.8	26	16
		500	21	34	20
		630	46	38	25
		800	68	42	30.2
		1000	94	46	37
400	0.0415	630	8	32	17.6
		800	17	36	22.2
		1000	31	39	28.4
		1250	58	43	34
		1600	80	46	40

Data were chosen when the air velocity is 2.5m/s and the velocity at throw distance is 0.25m/s.



JD-VC



JD-VF

- * They are used for long throw conditions with a 60° rotation angle.
- * They ensure a high air current in reduced pressure loss.
- * JD-VF has an inner core with a 360° horizontal rotation angle.
- * They can be multi design with a panel.
- * Material: They are made of aluminum sheet.
- * Mounting: Ceiling or wall mounting by screws, or collected into a circular duct.
- * Finishing: White powder coating Ral9016, Ral9010, or customized color.

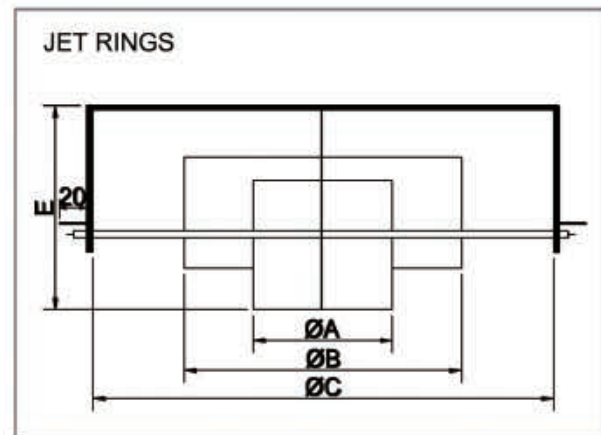
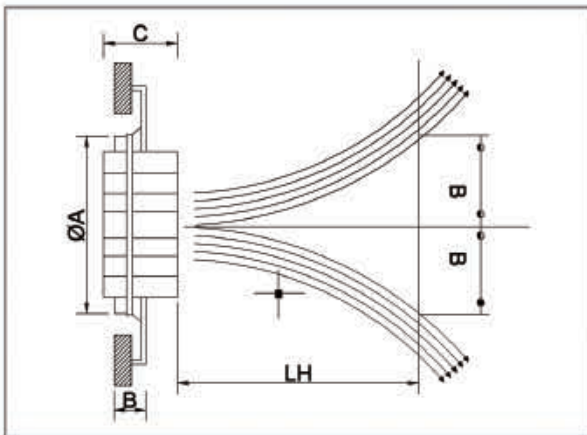

JD-VC Selection Table (JD-VC1/JD-VC2)

A	B	C _(JD-VC1)	C _(JD-VC2)
150	50	60	140
200	50	60	140
250	50	60	140
300	50	60	140
350	50	60	140
400	50	60	140

JD-VF Size Data

Size	A	B	C	D	E
150	95	-	150	155	145
200	95	150	190	205	155
250	95	180	250	260	155
315	100	200	285	295	155
350	100	225	335	340	155

Selection Table(JD-VC,JD-VF)

Neck Size (mm)	Effective Area(m ²)	Neck Vel (m/s)	2	3	4	5	6	7	8	10
150	0.018	M3H	127	191	254	318	382	445	509	636
		Throw(m)	2.6	4	5.5	6.8	8.2	9.6	11	15.2
		NC	-	20	24	30	37	43	47	50
200	0.031	M3H	226	339	452	565	679	792	905	1131
		Throw(m)	3.8	5.6	7.4	9.2	11	13	14.7	20.5
		NC	-	20	24	30	37	43	47	50
250	0.049	M3H	353	530	707	884	1060	1237	1414	1767
		Throw(m)	4.6	7	9.5	11.6	13.8	16.2	18.5	25.4
		NC	-	-	22	27	32	36	40	44
300	0.071	M3H	509	763	1018	1272	1527	1781	2036	2545
		Throw(m)	5.6	8.4	11.2	14	16.8	19.5	22.2	31
		NC	-	-	23	27	32	36	40	44
350	0.096	M3H	693	1039	1385	1732	2078	2425	2771	3464
		Throw(m)	6.5	9.6	13	16.3	19.5	22.6	25.6	35.5
		NC	-	-	24	28	34	37	41	45
400	0.126	M3H	905	1358	1810	2260	2715	3168	3619	4525
		Throw(m)	7.4	10.8	15.2	18.8	22.4	26.4	29.4	33.1
		NC	20	22	25	35	39	44	51	60



- * Drum jet diffuser is designed to meet the requirements of low pressure drop, quiet operations, long distance throw and good air spread in large areas.
- * The air flow direction can be oriented up and down by rotating the cylindrical inner casing in a 60° angle.
- * The air flow direction can be oriented left and right by adjusting the blades on the inner casing.
- * Material: They are made of aluminum sheet.
- * Mounting: wall mounting by screws, or collected into a rectangular or circular duct.
- * Finishing: White powder coating Ra19016, Ra19010, or customized color.

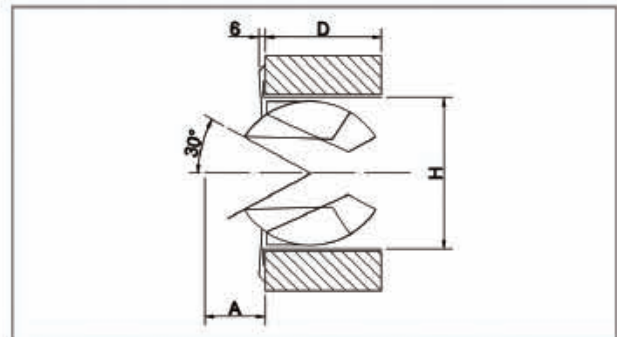
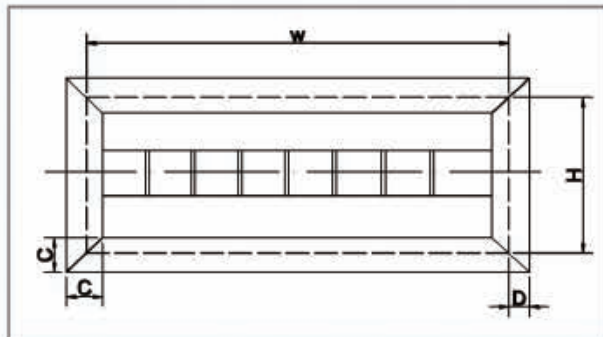

Selection table

Standard size (mm)	Air Volume(m3)	Throw(m)
300x150	350 ~ 800	6 ~ 16
375x150	450 ~ 1100	6 ~ 17
450x150	500 ~ 1300	6 ~ 17
600x150	600 ~ 1900	6 ~ 20
750x150	750 ~ 2300	6 ~ 21
900x150	800 ~ 2800	6 ~ 23
600x250	1700 ~ 3500	18 ~ 33
750x250	2000 ~ 4500	18 ~ 35
900x250	2200 ~ 5000	18 ~ 38
1050x250	2500 ~ 6000	18 ~ 40
1200x250	3000 ~ 7000	18 ~ 43
1350x250	3200 ~ 7500	18 ~ 43
1500x250	3400 ~ 8500	18 ~ 43



- * They are used as supply diffuser on air duct systems
- * They are ideal for the place with large space needs high air volume
- * The blades distance is adjustable for cooling and heating.
- * Accessories: slide damper
- * Material: Made of aluminium sheet.
- * Finishing: White powder coating Ral9016, Ral9010, or customized color.

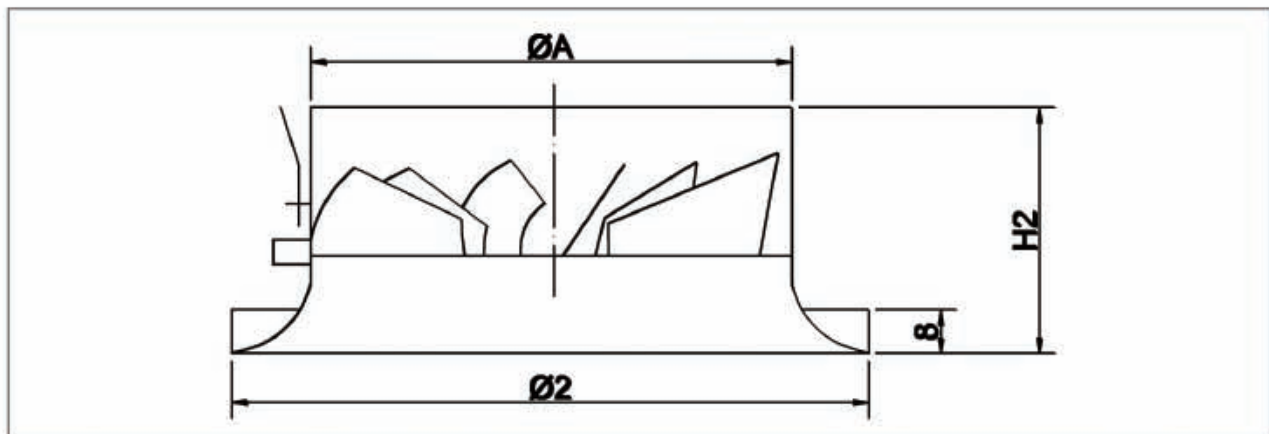

Selection table:

MOTEL	A	Q2	H2	Air Flow Volume(m3/h)	Throw (m)
200	200	300	145	450	3.5 ~ 17.1
250	250	360	166	750	3.6 ~ 17.9
315	315	465	200	2000	3.7 ~ 18.7
400	400	568	236	2500	3.8 ~ 19.2
500	500	718	260	3000	3.9 ~ 19.6
630	600	878	304	3500	4.0 ~ 19.8

Model	Technical data for heating, blades with equal distance										
200	Velocity	m/s	2	3	4	5	6	7	8	9	10
	Air Flow	m ³ /h	555	830	1107	1384	1660	1938	2210	2491	2780
	Pressure	Pa	13	27	43	62	83	108	135	163	192
	Noise level	Db(A)	35	38	41	44	47	50	53	56	59
	Technical data for cooling, blades with max opening										
	Velocity	m/s	2	3	4	5	6	7	8	9	10
	Air Flow	m ³ /h	555	830	1107	1384	1660	1938	2210	2491	2780
	Pressure	Pa	25	53	88	130	182	239	303	375	451
	Noise level	Db(A)	36	39	42	45	49	53	56	60	63
	Max Throw	m	3.5	4.9	6.6	8.1	9.8	11.9	13.6	15.3	17.1
250	Technical data for heating, blades with equal distance										
	Velocity	m/s	2	3	4	5	6	7	8	9	10
	Air Flow	m ³ /h	348	520	65	869	1043	1216	1389	1563	1738
	Pressure	Pa	12	23	37	53	71	91	112	135	160
	Noise level	Db(A)	36	39	42	45	48	51	54	57	60
	Technical data for cooling, blades with max opening										
	Velocity	m/s	2	3	4	5	6	7	8	9	10
	Air Flow	m ³ /h	348	520	65	869	1043	1216	1389	1563	1738
	Pressure	Pa	20	42	70	104	143	187	237	292	351
	Noise level	Db(A)	37	40	43	46	50	53	56	59	63
Max Throw	m	3.6	5.4	7.2	9.0	10.8	12.6	14.4	16.2	17.9	
315	Technical data for heating, blades with equal distance										
	Velocity	m/s	2	3	4	5	6	7	8	9	10
	Air Flow	m ³ /h	555	830	1107	1384	1660	1938	2210	2491	2780
	Pressure	Pa	13	27	43	62	83	108	135	163	192
	Noise level	Db(A)	35	38	41	44	47	50	53	56	59
	Technical data for cooling, blades with max opening										
	Velocity	m/s	2	3	4	5	6	7	8	9	10
	Air Flow	m ³ /h	555	830	1107	1384	1660	1938	2210	2491	2780
	Pressure	Pa	25	53	88	130	182	239	303	375	451
	Noise level	Db(A)	36	39	42	45	49	53	56	60	63
Max Throw	m	3.7	5.6	7.5	9.3	11.2	13.1	14.9	16.8	18.7	
400	Technical data for heating, blades with equal distance										
	Velocity	m/s	2	3	4	5	6	7	8	9	10
	Air Flow	m ³ /h	895	1343	1791	2238	2686	3581	3529	4029	4476
	Pressure	Pa	16	31	50	73	99	128	160	195	231
	Noise level	Db(A)	33	37	41	46	51	56	61	66	71
	Technical data for cooling, blades with max opening										
	Velocity	m/s	2	3	4	5	6	7	8	9	10
	Air Flow	m ³ /h	895	1343	1791	2238	2686	3581	3529	4029	4476
	Pressure	Pa	32	66	111	165	229	302	384	474	573
	Noise level	Db(A)	34	38	43	48	53	58	63	68	73
Max Throw	m	3.8	5.8	7.7	9.6	11.5	13.5	15.4	17.3	19.2	

Model	Technical data for heating, blades with equal distance										
500	Velocity	m/s	2	3	4	5	6	7	8	9	10
	Air Flow	m ³ /h	1402	2103	2803	3503	4205	4906	5607	6308	7006
	Pressure	Pa	18	35	58	84	115	149	186	227	270
	Noise level	Db(A)	32	36	40	45	50	55	60	65	70
	Technical data for cooling, blades with max opening										
	Velocity	m/s	2	3	4	5	6	7	8	9	10
	Air Flow	m ³ /h	1402	2103	2803	3503	4205	4906	5607	6308	7006
	Pressure	Pa	39	81	136	203	282	372	473	585	707
	Noise level	Db(A)	33	37	42	47	52	57	62	67	72
	Max Throw	m	3.9	5.9	7.8	9.8	11.7	13.7	15.7	17.6	19.6
630	Technical data for heating, blades with equal distance										
	Velocity	m/s	2	3	4	5	6	7	8	9	10
	Air Flow	m ³ /h	2229	3344	4458	5573	6687	7801	8916	10031	11145
	Pressure	Pa	20	40	66	97	132	172	216	263	314
	Noise level	Db(A)	38	42	46	51	56	61	66	71	76
	Technical data for cooling, blades with max opening										
	Velocity	m/s	2	3	4	5	6	7	8	9	10
	Air Flow	m ³ /h	2229	3344	4458	5573	6687	7801	8916	10031	11145
	Pressure	Pa	47	98	166	249	346	457	582	720	871
	Noise level	Db(A)	39	43	48	53	58	63	68	73	78
Max Throw	m	4.0	5.9	7.9	9.9	11.9	13.9	15.9	17.8	19.8	

SQUARE SWIRL DIFFUSER



- * They are used as supply diffuser on the ceiling.
- * They are ideal for the place needs high air volume.
- * They can be used between 2.6m and 4m height.
- * Accessories: Plenum box, round slide damper.
- * Finishing: White powder coating Ral9016, Ral9010, or customized color.

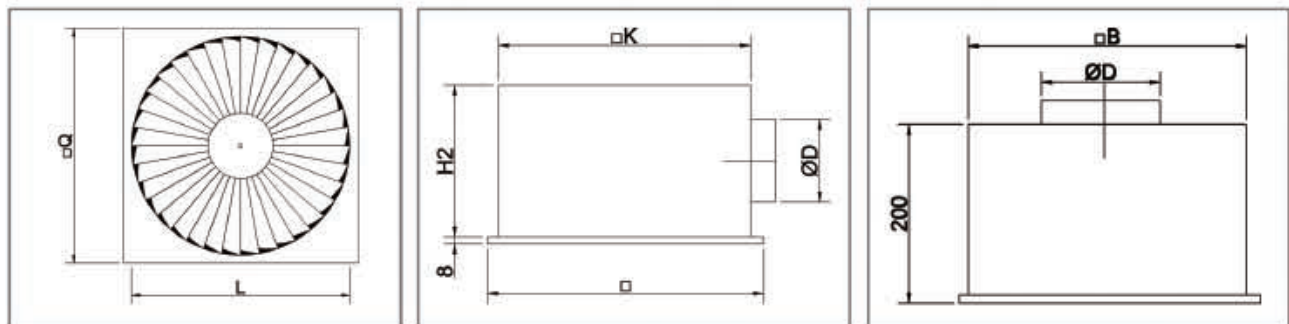

Selection Tables

Standard size	Effective Area (m ²)	B	D	L	Q	H2	K	Air volume(m ³ /h)
300x300	0.009	280	148	250	295	250	290	145-200
400x400	0.018	364	198	350	395	295	372	180-400
500x500	0.025	462	198	450	495	295	476	215-520
595x595	0.030	559	248	538	595	345	567	290-600
600x600	0.030	559	248	538	598	345	567	290-600
625x625	0.030	559	248	538	623	345	567	290-600

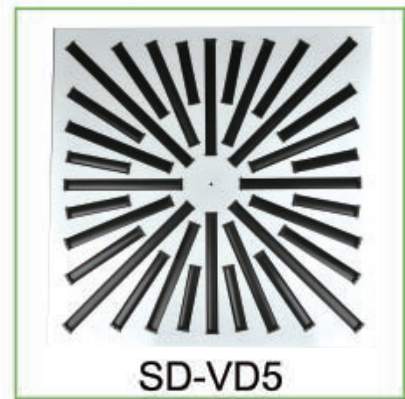

- * They are used as supply and return diffuser on the ceiling.
- * They are with adjustable black plastic blades
- * They can be used between 2.6m and 4m height.
- * Accessories: Plenum box, round slide damper.
- * Finishing: White powder coating Ral9016, Ral9010, or customized color.

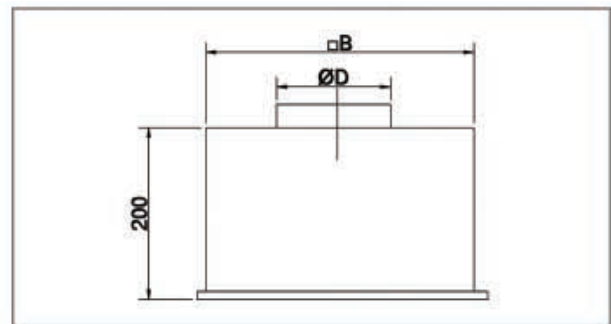
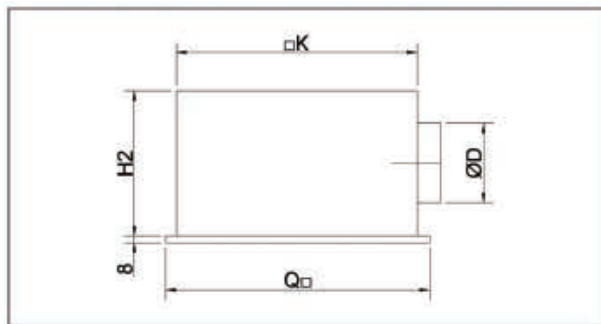

Selection Tables

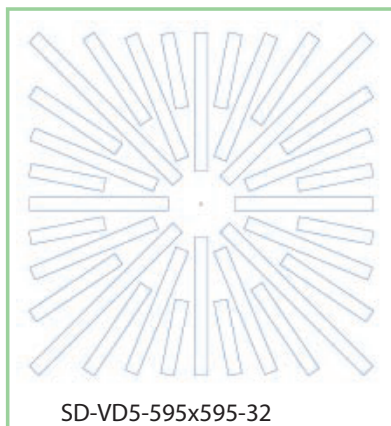
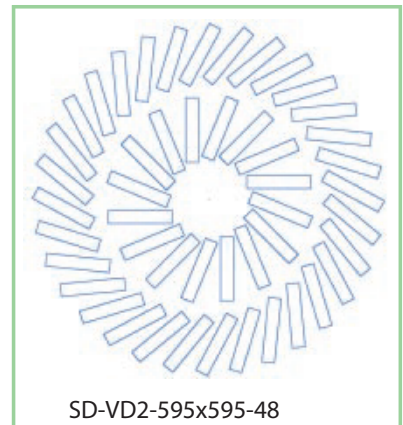
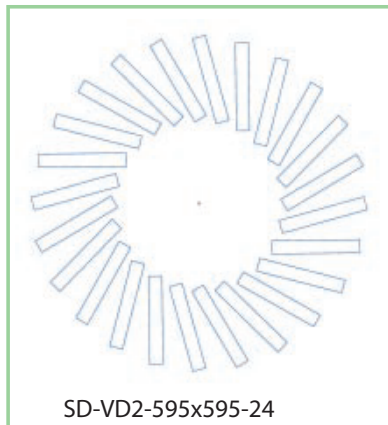
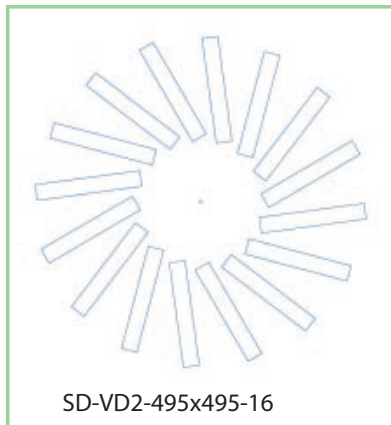
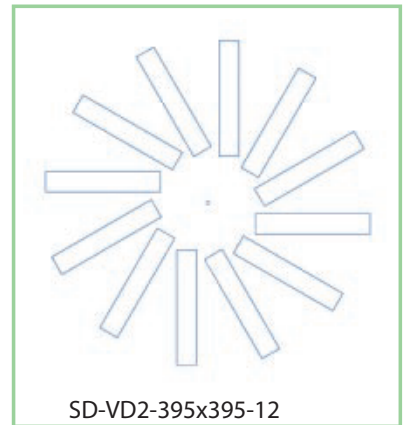
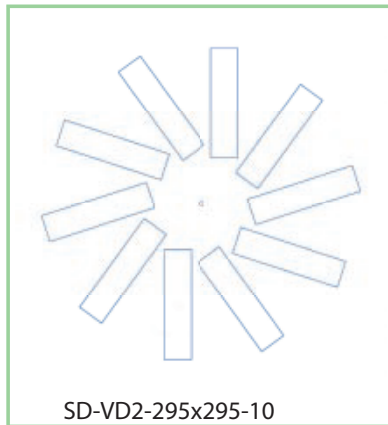
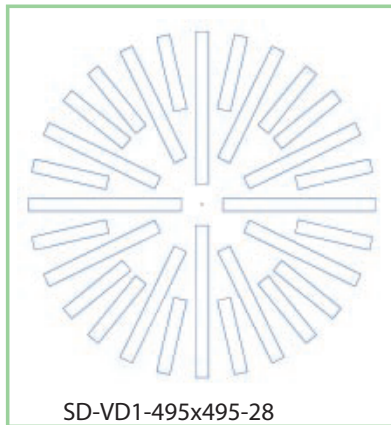
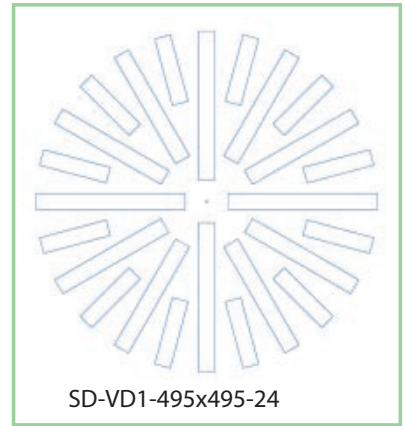
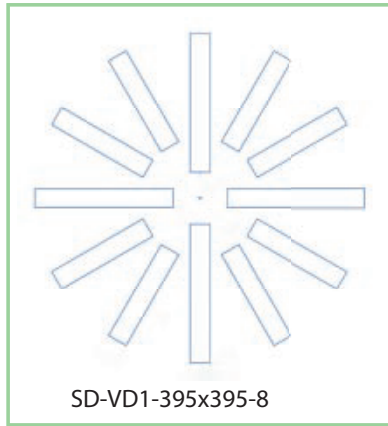
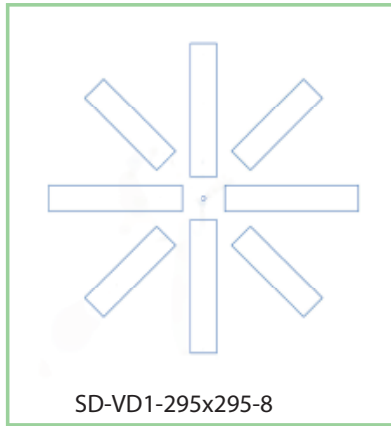

Model	Standard size	B	D	L	Q	H2	K	Air volume(m3/h)
SD-VD1	295x295-8	280	148	250	295	250	290	55-250
SD-VD1	395x395-12	364	198	350	395	295	372	100-400
SD-VD1	495x495-24	462	198	450	495	295	476	140-470
SD-VD1	595x595-28	559	248	538	595	345	567	250-730
SD-VD2	295x295-10	280	148	250	295	250	290	150-410
SD-VD2	395x395-12	364	198	350	395	295	372	170-490
SD-VD2	495x495-24	462	198	450	495	295	476	300-980
SD-VD2	595x595-48	559	248	538	595	345	567	360-1380
SD-VD5	595x595-32	559	248	538	595	345	567	420-1600

SQUARE SWIRL DIFFUSER

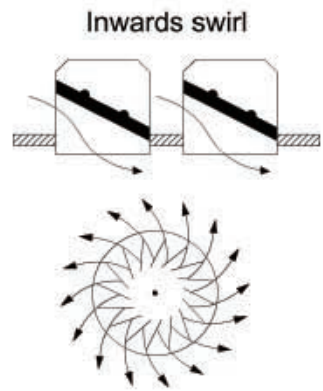



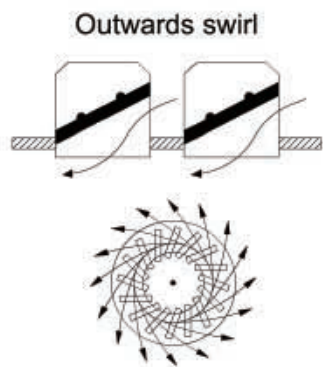
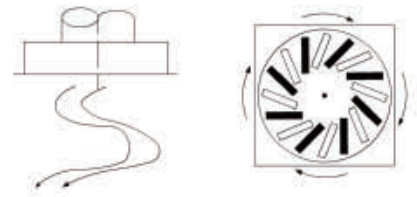

All air control blades set to external swirl

-  Biade position 1
-  Biade position 2



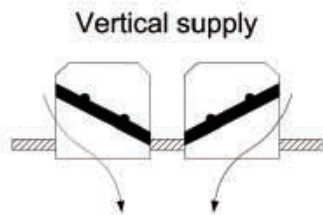
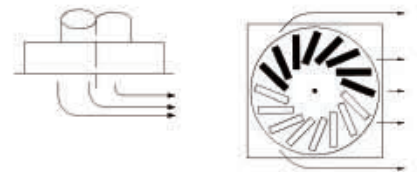

Air control blades set to external and half internal to swirl

-  Biade position 1
-  Biade position 2



Air flow is orientated in two direction by blades

-  Biade position 1
-  Biade position 2

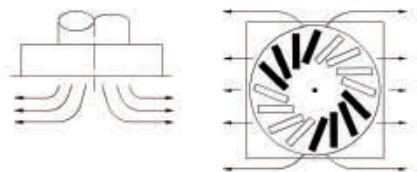

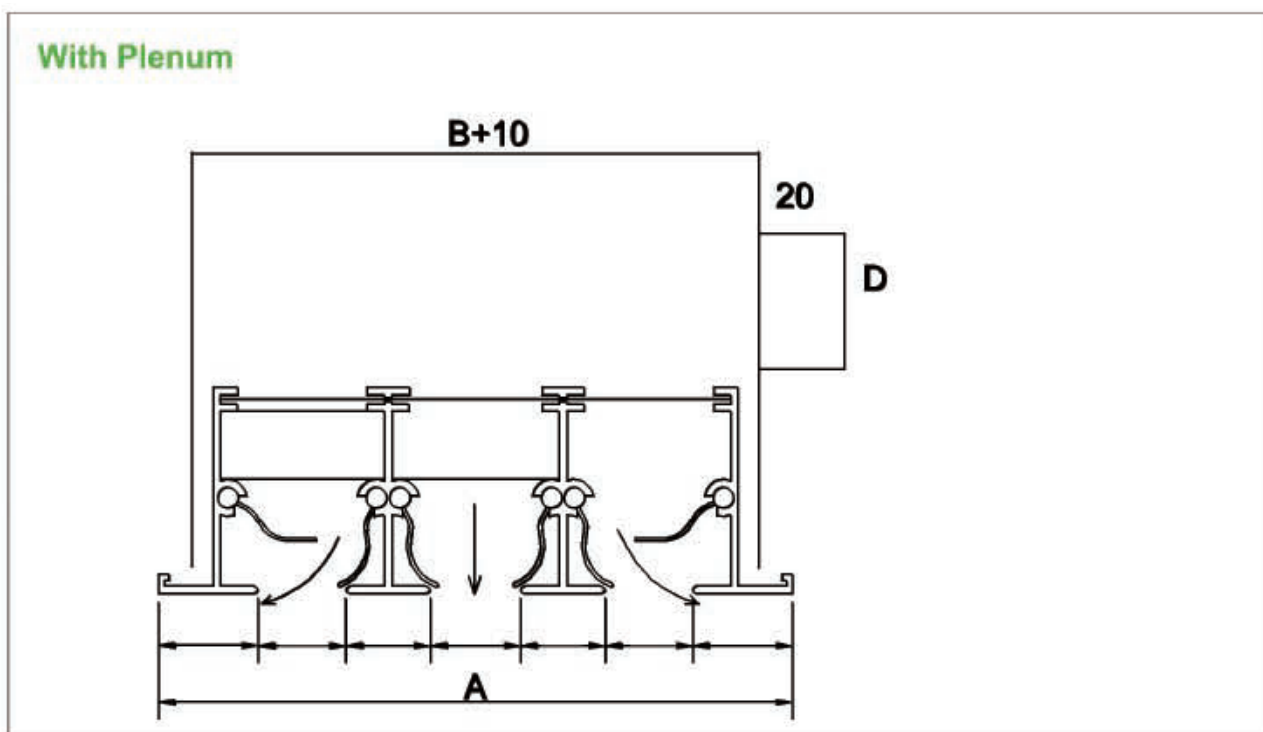

- * These slot diffusers are available in 1-6 slots. 19mm or 25mm slot size.
- * They can be mounted on wall or ceiling.
- * They can be used in rooms with ceiling heights from approx. 2.6 m to 4.0 m
- * The direction of the air discharge can be adjusted by rotating the air control blades.
- * Accessories: Plenum box.
- * Finishing: White powder coating Ral9016, Ral9010, or customized color.

Size Table

LSD-VA

Slot Distance	Slots	A	B	H
20	1	84	40	49
	2	120	76	49
	3	155	111	49
	4	191	147	49
	5	226	182	49
	6	262	218	49
25	1	89	45	49
	2	130	86	49
	3	170	126	49
	4	211	167	49
	5	251	207	49
	6	292	248	49

LSD-VB

Slots	Slot Distance	A	B	H
2	20	144	94	55
2	25	154	104	55

LSD-VC

Slot Distance	Slots	A	B	H
20	1	75	40	45
	2	114	79	45
	3	153	118	45
	4	192	157	45
	5	231	196	45
	6	270	235	45
25	1	80	45	45
	2	124	89	45
	3	168	133	45
	4	212	177	45
	5	256	221	45
	6	300	265	45

LSD-VD

Slat Distance	Slats	A	B	H
20	1	60	36	30
	2	100	76	30
	3	140	116	30
	4	180	156	30
	5	220	196	30
	6	260	226	30
25	1	65	41	30
	2	110	86	30
	3	155	131	30
	4	200	176	30
	5	245	221	30
	6	290	266	30

Performance Data (20mm slot)

1 slot	Airflow(m ³ /h)	33	66	106	140	173	206	240	279	312
	Static pressure	0.10	0.41	0.94	1.65	2.58	3.71	5.05	6.60	8.38
	NC			14	20	26	30	34	37	40
	Throw(m)	1	2	3	4	4	5	5	5	5
2slots	Airflow(m ³ /h)	67	139	205	278	348	413	485	552	625
	Static pressure	0.10	0.41	0.94	1.65	2.58	3.71	5.05	6.60	8.38
	NC			17	23	29	33	37	40	43
	Throw(m)	1	3	4	5	6	6	7	7	8
3slots	Airflow(m ³ /h)	105	205	312	415	520	625	725	830	932
	Static pressure	0.10	0.41	0.94	1.65	2.58	3.71	5.05	6.60	8.38
	NC			18	25	31	35	39	42	45
	Throw(m)	2	3	5	6	7	8	9	9	10
4slots	Airflow(m ³ /h)	140	278	413	550	692	830	970	1105	1239
	Static pressure	0.10	0.41	0.94	1.65	2.58	3.71	5.05	6.60	8.38
	NC			20	26	32	36	40	43	46
	Throw(m)	2	4	6	7	8	9	10	10	11
5slots	Airflow(m ³ /h)	173	345	520	692	865	1038	1211	1385	1558
	Static pressure	0.10	0.41	0.94	1.65	2.58	3.71	5.05	6.60	8.38
	NC			21	27	33	37	41	44	47
	Throw(m)	2	4	6	8	9	10	11	12	12
6slots	Airflow(m ³ /h)	206	413	625	831	1038	1244	1451	1663	1869
	Static pressure	0.10	0.41	0.94	1.65	2.58	3.71	5.05	6.60	8.38
	NC			21	28	34	38	42	45	48
	Throw(m)	2	5	7	9	10	11	12	13	14

Performance Data (25mm slot)

1 slot	Airflow(m ³ /h)	39	73	112	145	183	222	256	296	329
	Static pressure	0.10	0.36	0.81	1.45	2.26	3.25	4.42	5.79	7.32
	NC			13	20	26	30	34	37	40
	Throw(m)	1	2	4	4	5	5	5	6	6
2slots	Airflow(m ³ /h)	73	145	223	296	368	441	513	590	665
	Static pressure	0.10	0.36	0.81	1.45	2.26	3.25	4.42	5.79	7.32
	NC			16	23	29	33	37	40	43
	Throw(m)	2	3	5	6	7	7	8	9	9
3slots	Airflow(m ³ /h)	112	223	329	440	550	664	776	881	990
	Static pressure	0.10	0.36	0.81	1.45	2.26	3.25	4.42	5.79	7.32
	NC			18	25	30	35	39	42	45
	Throw(m)	2	4	6	7	8	9	10	10	11
4slots	Airflow(m ³ /h)	145	296	440	590	738	881	1032	1177	1328
	Static pressure	0.10	0.36	0.81	1.45	2.26	3.25	4.42	5.79	7.32
	NC			19	26	32	36	40	43	46
	Throw(m)	2	5	7	9	9	10	11	12	13
5slots	Airflow(m ³ /h)	183	368	551	736	920	1105	1289	1473	1658
	Static pressure	0.10	0.36	0.81	1.45	2.26	3.25	4.42	5.79	7.32
	NC			20	27	33	37	41	44	47
	Throw(m)	3	5	8	9	10	12	12	13	14
6slots	Airflow(m ³ /h)	222	440	663	881	1105	1328	1546	1768	1986
	Static pressure	0.10	0.36	0.81	1.45	2.26	3.25	4.42	5.79	7.32
	NC			21	28	33	38	42	45	48
	Throw(m)	3	6	9	10	12	12	14	15	16

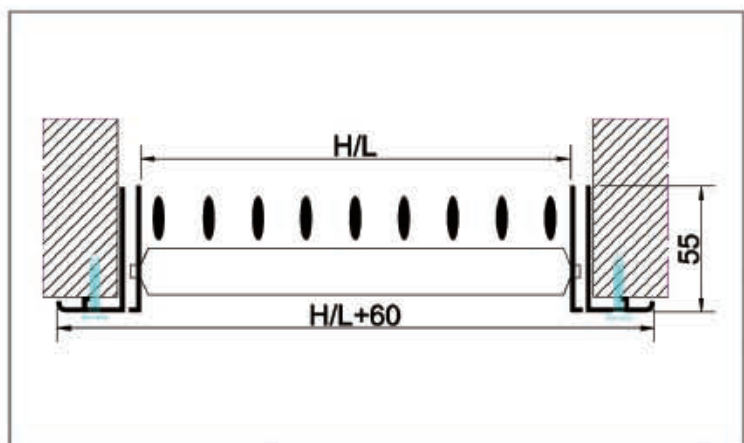
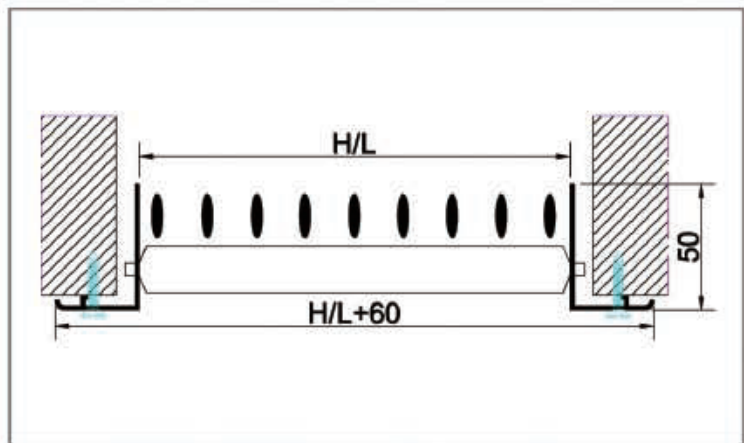
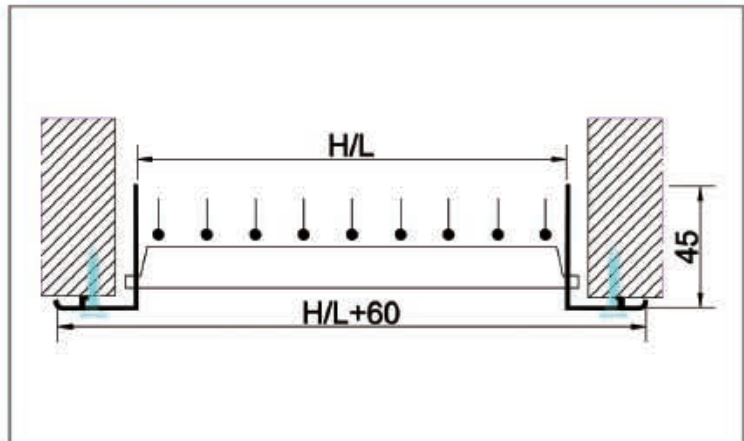

- * They are used as a supply grille
- * Their blades are adjustable horizontally and vertically.
- * Accessories: Damper, Plenum box
- * Mounting: Screw fixing is standard, concealed clip fixing as optional.
- * Finishing: White powder coating Ral9016, Ral9010, or customized color. Anodized.

LxH	100x	200			250			300			350			400		
M3/H	Deflection.	0	22.5	45	0	22.5	45	0	22.5	45	0	22.5	45	0	22.5	45
100	Vel	2.36	2.62	3.31	1.85	2.06	2.60	1.52	1.69	2.14	1.40	1.44	1.82	1.13	1.26	1.58
	P	0.33	0.41	0.66	0.21	0.25	0.41	0.14	0.17	0.28	0.11	0.12	0.20	0.08	0.09	0.15
	T	3.45	2.86	2.46	3.05	2.52	2.18	2.77	2.30	1.97	2.56	2.12	1.82	2.38	1.97	1.70
	dbA	15	15	15	15	15	15	15	15	15	15	15	15	15	15	15
200	Vel	4.72	5.24	6.63	3.70	4.12	5.20	3.05	3.39	4.28	2.59	2.88	3.64	2.25	2.50	3.16
	P	1.34	1.65	2.63	0.82	1.02	1.62	0.56	0.69	1.10	0.40	0.50	0.79	0.30	0.38	0.60
	T	6.90	5.71	4.91	6.11	5.06	4.35	5.55	4.59	3.95	5.11	4.23	3.64	4.77	3.95	3.39
	dbA	18	19	20	16	17	18	15	15	15	17	15	15	15	15	15
300	Vel	7.08	7.87	9.94	5.56	6.18	7.80	4.57	5.08	6.42	3.89	4.32	5.46	3.38	3.76	4.75
	P	3.00	3.71	5.93	1.85	2.29	3.65	1.26	1.55	2.48	0.91	1.12	1.79	0.69	0.85	1.35
	T	10.35	8.75	7.37	9.17	7.59	6.53	8.32	6.89	5.92	7.67	6.35	5.46	7.15	5.92	5.09
	dbA	25	26	28	23	24	26	22	23	25	20	21	23	19	20	22
400	Vel	9.44	10.49	13.25	7.41	8.23	10.40	6.10	6.78	8.57	5.18	5.76	7.28	4.51	5.01	6.33
	P	5.34	6.60	10.53	3.29	4.07	6.49	2.22	2.78	4.40	1.60	1.99	3.19	1.22	1.51	2.41
	T	13.78	11.43	9.83	12.22	10.12	8.71	11.09	9.18	7.90	10.22	8.46	7.28	9.53	7.98	6.78
	dbA	31	32	33	29	30	32	27	28	30	26	27	29	24	25	28
500	Vel	11.79	13.11	16.56	9.26	10.29	13.01	7.62	8.47	10.71	6.48	7.20	9.10	5.63	6.26	7.91
	P	8.35	10.31	16.46	5.15	6.36	10.15	3.49	4.31	6.88	2.52	3.11	4.97	1.90	2.35	3.75
	T	17.24	14.28	12.28	15.29	12.66	10.89	13.86	11.48	9.87	12.78	10.58	9.10	11.92	9.86	8.49
	dbA	36	36	38	34	35	36	32	33	35	30	31	34	29	30	32
600	Vel	14.15	15.73	19.88	11.11	12.35	15.61	9.15	10.17	12.85	7.77	8.64	10.92	6.76	7.51	9.49
	P	12.02	14.85	23.70	7.41	9.15	14.62	5.02	6.20	9.90	3.63	4.48	7.15	2.74	3.39	5.40
	T	20.69	17.13	14.74	18.34	15.18	13.06	16.65	13.77	11.85	15.34	12.70	10.92	14.31	11.85	10.18
	dbA	40	40	42	38	39	40	36	37	39	34	35	37	33	34	36
700	Vel	16.51	18.35	23.19	12.97	14.41	18.21	10.67	11.86	14.99	9.07	10.08	12.74	7.89	8.76	11.07
	P	16.36	20.21	32.26	10.09	12.46	19.89	6.84	8.44	13.48	4.94	6.10	9.73	3.73	4.61	7.36
	T	24.14	19.99	17.19	21.39	17.71	15.24	19.41	16.07	13.82	17.89	14.81	12.74	16.68	13.81	11.88
	dbA	43	44	45	41	42	44	39	40	42	38	39	41	36	37	40
800	Vel	18.87	20.98	26.50	14.82	16.47	20.81	12.20	13.56	17.13	10.37	11.52	14.56	9.01	10.02	12.66
	P	21.37	26.39	41.15	13.18	16.28	25.98	8.93	11.03	17.61	6.45	7.96	12.71	4.87	6.02	9.61
	T										20.45	18.93	14.56	19.06	15.78	13.58
	dbA										41	42	44	39	40	43
900	Vel										11.66	12.96	16.38	10.15	11.27	14.25
	P										8.16	10.08	16.09	6.17	7.62	12.16
	T										23.00	19.04	16.38	21.45	17.76	15.28
	dbA										43	44	47	42	43	45
1000	Vel										12.96	14.40	18.20	11.26	12.52	15.83
	P										10.07	12.44	19.87	7.61	9.40	15.01
	T										25.56	21.16	18.20	23.83	19.73	16.97
	dbA										46	47	49	44	45	48

LxH		150x			200			250			300			350			400		
M3/H	Deflection.	0	22.5	45	0	22.5	45	0	22.5	45	0	22.5	45	0	22.5	45			
100	Vel	1.47	1.63	2.07	1.15	1.28	1.62	0.95	1.06	1.34	0.81	0.90	1.13	0.7	0.78	0.99			
	P	0.13	0.16	0.26	0.08	0.10	0.16	0.05	0.07	0.11	0.04	0.05	0.08	0.03	0.04	0.06			
	T	2.72	2.25	1.94	2.41	2.00	1.72	2.19	1.81	1.56	2.02	1.67	1.44	1.88	1.56	1.34			
	dbA	15	15	15	15	15	15	15	15	15	15	15	15	15	15	15			
200	Vel	2.94	3.27	4.13	2.31	2.57	3.24	1.90	2.11	2.67	1.62	1.80	2.27	1.40	1.56	1.97			
	P	0.52	0.64	1.02	0.32	0.40	0.63	0.22	0.27	0.43	0.16	0.19	0.31	0.12	0.15	0.23			
	T	5.45	4.51	3.88	4.83	4.00	3.44	4.38	3.62	3.12	4.04	3.34	2.87	3.76	3.12	2.68			
	dbA	15	15	17	15	15	15	15	15	15	15	15	15	15	15	15			
300	Vel	4.41	4.90	6.20	3.46	3.85	4.87	2.85	3.17	4.01	2.42	2.69	3.40	2.11	2.34	2.96			
	P	1.17	1.44	2.30	0.72	0.89	1.42	0.49	0.60	0.96	0.35	0.44	0.70	0.27	0.33	0.53			
	T	8.17	6.76	5.82	7.24	5.99	5.16	6.57	5.44	4.68	6.05	5.01	4.31	5.56	4.67	4.02			
	dbA	21	22	24	19	20	22	17	18	20	15	16	16	15	15	17			
400	Vel	5.88	6.54	8.26	4.62	5.13	6.49	3.80	4.23	5.34	3.23	3.59	4.55	2.80	3.12	3.95			
	P	2.08	2.57	3.10	1.28	1.58	2.53	0.87	1.07	1.71	0.63	0.77	1.24	0.47	0.58	0.93			
	T	10.89	9.02	7.76	9.65	7.99	6.87	8.76	7.25	6.24	8.07	6.68	5.75	7.53	6.23	5.36			
	dbA	27	28	30	25	26	28	22	24	26	20	22	24	18	20	23			
500	Vel	7.35	8.17	10.33	5.77	6.42	8.11	4.75	5.28	6.68	4.04	4.49	5.66	3.50	3.90	4.92			
	P	3.24	4.00	6.40	2.01	2.47	3.95	1.36	1.67	2.67	0.98	1.21	1.93	0.74	0.91	1.46			
	T	13.62	11.27	9.70	12.06	9.99	8.59	10.95	9.06	7.80	10.09	8.35	7.19	9.41	7.79	6.70			
	dbA	32	33	35	29	30	33	27	28	31	25	26	29	23	25	27			
600	Vel	8.82	9.81	12.39	6.93	7.70	9.73	5.70	6.34	8.01	4.85	5.39	6.81	4.20	4.68	5.92			
	P	4.67	5.77	9.21	2.88	3.56	5.68	1.95	2.41	3.85	1.41	1.74	2.78	1.07	1.32	2.10			
	T	14.34	13.53	11.64	14.48	11.99	10.31	13.14	10.87	9.36	13.11	10.02	8.62	11.29	9.35	8.04			
	dbA	36	37	39	33	34	36	31	32	35	29	30	33	27	28	31			
700	Vel	10.30	11.44	14.46	8.08	8.89	11.35	6.65	7.40	9.35	5.66	6.29	7.94	4.92	5.46	6.90			
	P	6.36	7.86	12.54	3.92	4.84	7.73	2.66	3.28	5.24	1.92	2.37	3.78	1.45	1.79	2.86			
	T	19.06	15.78	13.58	16.89	13.98	12.03	15.32	12.69	10.92	14.13	11.70	10.06	13.17	10.91	9.38			
	dbA	39	40	42	36	38	40	34	36	38	32	34	36	30	32	35			
800	Vel	11.77	13.08	16.52	9.24	10.27	12.97	7.61	8.45	10.68	6.46	7.18	9.08	5.62	6.24	7.89			
	P	8.31	10.26	16.38	5.12	6.33	10.10	3.47	4.29	6.83	2.51	3.10	4.92	1.89	2.33	3.75			
	T	21.78	18.03	15.52	19.30	15.98	13.75	17.51	14.50	12.47	16.15	13.37	11.50	13.05	12.46	10.72			
	dbA	42	43	45	39	41	43	37	39	41	35	37	39	33	35	38			
900	Vel	13.24	14.71	18.59	10.39	11.55	14.60	8.56	9.51	10.02	7.27	8.08	10.21	6.32	7.03	8.88			
	P	10.51	12.99	20.73	6.48	8.01	12.78	4.39	5.43	8.55	3.17	3.92	6.26	2.40	2.96	4.73			
	T	24.51	20.29	17.46	21.27	17.98	15.47	19.70	16.31	14.03	18.16	15.03	12.94	16.95	14.02	12.06			
	dbA	45	46	48	42	43	46	40	41	44	38	39	42	36	38	40			
1000	Vel					12.84	16.22	9.51	10.57	13.35	8.08	8.98	11.35	7.02	7.81	9.86			
	P					9.98	15.78	5.43	6.70	10.69	3.92	4.48	7.72	2.96	3.66	5.84			
	T					19.98	17.19	21.89	18.12	15.59	20.18	16.71	14.37	18.82	15.58	13.40			
	dbA					46	48	42	44	46	40	42	44	39	40	43			
1200	Vel										9.69	10.77	13.61	8.43	9.37	11.83			
	P										5.63	6.98	11.12	4.26	5.26	8.41			
	T										24.22	20.05	17.25	22.58	18.69	16.08			
	dbA										45	46	49	43	44	47			

LxH	200x	200			250			300			350			400		
M3/H	Deflection.	0	22.5	45	0	22.5	45	0	22.5	45	0	22.5	45	0	22.5	45
100	Vel	1.07	1.19	1.50	0.84	0.93	1.18	0.69	0.77	0.97	0.59	0.65	0.82	0.51	0.57	0.72
	P	0.07	0.08	0.14	0.04	0.05	0.08	0.03	0.04	0.06	0.02	0.03	0.04	0.02	0.02	0.03
	T	2.32	1.92	1.65	2.06	1.70	1.46	1.87	1.54	1.33	1.72	1.42	1.23	1.60	1.33	1.14
	dbA	15	15	15	15	15	15	15	15	15	15	15	15	15	15	15
200	Vel	2.14	2.38	3.00	1.68	1.86	2.36	1.38	1.54	1.94	1.17	1.30	1.65	1.03	1.13	1.43
	P	0.27	0.34	0.54	0.17	0.21	0.33	0.11	0.14	0.23	0.08	0.10	0.16	0.06	0.08	0.12
	T	4.64	3.84	3.31	4.11	3.41	2.93	3.73	3.09	2.66	3.44	2.85	2.45	3.21	2.66	2.28
	dbA	15	15	15	15	15	15	15	15	15	15	15	15	15	15	15
300	Vel	3.21	3.56	3.50	2.52	2.81	3.53	2.07	2.30	2.91	1.76	1.96	2.47	1.53	1.70	2.15
	P	0.62	0.76	1.22	0.38	0.47	0.75	0.26	0.32	0.51	0.19	0.23	0.37	0.14	0.17	0.28
	T	6.96	5.76	4.96	6.18	5.11	4.39	5.60	4.63	3.99	5.16	4.27	3.68	4.81	3.98	3.43
	dbA	18	19	22	15	16	19	15	15	17	15	15	15	15	15	15
400	Vel	4.27	4.75	6.00	3.36	3.73	4.71	2.76	3.07	3.88	2.35	2.61	3.30	2.03	2.28	2.87
	P	1.10	1.35	2.16	0.68	0.83	1.33	0.46	0.57	0.90	0.33	0.41	0.65	0.25	0.31	0.49
	T	9.28	7.69	6.61	8.23	6.81	5.86	7.46	6.18	5.32	6.88	5.70	4.90	6.42	5.33	4.57
	dbA	24	25	27	21	22	25	18	20	23	16	17	21	15	15	19
500	Vel	5.34	5.93	7.50	4.19	4.66	5.89	3.45	3.84	4.85	2.93	3.26	4.12	2.55	2.83	3.58
	P	1.17	2.12	3.38	1.06	1.30	2.08	0.72	0.88	1.41	0.53	0.64	1.02	0.39	0.48	0.77
	T	11.60	9.61	8.27	10.28	8.51	7.32	9.33	7.72	6.65	8.60	7.12	6.13	8.02	6.64	5.71
	dbA	28	30	32	25	27	29	23	24	27	21	22	25	18	20	23
600	Vel	6.41	7.13	9.00	5.03	5.59	7.08	4.14	4.61	5.82	3.53	3.91	4.95	3.06	3.40	4.30
	P	2.48	3.05	4.86	1.52	1.88	3.00	1.03	1.28	2.03	0.74	0.92	1.47	0.56	0.69	1.11
	T	13.93	11.53	9.92	12.33	10.22	8.79	1.20	9.27	7.97	10.32	8.54	7.35	9.62	7.97	6.85
	dbA	32	33	36	29	31	33	27	28	31	24	26	29	22	24	27
700	Vel	7.48	8.31	10.50	5.87	6.53	8.25	4.83	5.37	6.79	4.11	4.57	5.57	3.58	3.98	5.02
	P	3.36	4.15	6.62	2.08	2.56	4.08	1.40	1.73	2.77	1.01	1.25	2.00	0.77	0.95	1.51
	T	16.25	13.45	11.58	14.40	11.93	10.25	3.06	10.81	9.30	12.05	9.98	8.58	11.23	9.29	8.00
	dbA	36	37	39	33	34	37	30	32	35	28	29	33	26	27	31
800	Vel	8.55	9.50	12.00	6.71	7.46	9.43	5.53	6.14	7.76	4.70	5.22	6.59	4.08	5.54	5.73
	P	4.38	5.42	8.65	2.70	3.33	5.33	1.84	2.26	3.61	1.32	1.63	2.61	1.00	1.23	1.97
	T	18.57	15.37	13.22	16.45	13.62	11.72	4.93	12.36	10.63	13.76	11.39	9.80	12.83	10.62	9.14
	dbA	39	40	42	36	37	40	33	35	38	31	32	36	29	30	34
900	Vel	9.62	10.69	13.50	7.55	8.39	10.60	6.22	6.90	8.74	5.38	5.88	7.42	4.59	5.10	6.46
	P	5.55	6.85	10.95	3.43	4.23	6.75	3.32	2.86	4.57	1.68	2.08	3.30	1.28	1.56	2.50
	T	20.89	17.29	14.88	18.51	15.32	13.18	6.79	12.70	11.96	15.48	12.833	11.03	14.43	11.95	10.28
	dbA	41	42	45	38	40	42	36	37	40	34	35	38	31	33	36
1000	Vel	10.68	11.88	15.00	8.39	9.32	11.78	6.91	7.68	9.70	5.88	6.52	8.25	5.10	5.68	7.18
	P	6.85	8.46	13.51	4.22	5.22	8.33	2.87	3.55	5.65	2.08	2.55	4.08	1.56	1.94	3.08
	T	23.21	19.21	16.53	20.57	17.05	14.65	8.66	15.45	13.29	17.20	14.25	12.25	16.05	13.28	11.43
	dbA	44	45	47	41	42	45	38	40	43	36	38	41	34	35	39
1200	Vel				10.08	11.19	14.15	8.29	9.21	11.64	7.05	7.83	9.89	6.12	6.81	8.60
	P				6.08	7.51	11.99	4.12	5.09	8.13	2.98	3.68	5.88	2.25	2.78	4.44
	T				24.68	20.43	17.58	12.39	19.54	15.95	20.64	17.09	14.70	19.25	15.94	13.71
	dbA				45	47	49	43	44	47	40	42	45	38	41	43

LxH	250x	200			250			300			350			400		
		M3/H	Deflection.	0	22.5	45	0	22.5	45	0	22.5	45	0	22.5	45	0
100	Vel	0.66	0.73	0.93	0.54	0.60	0.76	0.46	0.51	0.65	0.40	0.45	0.56	0.35	0.39	0.50
	P	0.03	0.03	0.05	0.02	0.02	0.03	0.01	0.02	0.03	0.01	0.01	0.02	0.01	0.01	0.01
	T	1.82	1.51	1.30	1.65	1.38	1.18	1.52	1.26	1.09	1.42	1.18	1.01	1.35	1.11	0.95
	dbA	15	15	15	15	15	15	15	15	15	15	15	15	15	15	15
200	Vel	1.32	1.46	1.85	1.08	1.21	1.52	0.92	1.02	1.92	0.80	0.89	1.13	0.71	0.79	1.00
	P	0.10	0.13	0.21	0.07	0.09	0.14	0.05	0.06	0.10	0.04	0.05	0.08	0.03	0.04	0.06
	T	3.64	3.02	2.60	3.31	3.75	2.36	3.05	2.52	2.18	2.84	2.35	2.03	2.68	2.21	1.90
	dbA	15	15	15	15	15	15	15	15	15	15	15	15	15	15	15
300	Vel	1.98	2.20	2.78	1.63	1.81	2.28	1.38	1.55	1.95	1.20	1.33	1.69	1.06	1.18	1.49
	P	0.23	0.29	0.46	0.16	0.20	0.31	0.11	0.14	0.23	0.09	0.11	0.17	0.07	0.08	0.13
	T	5.47	4.53	3.89	4.96	4.11	3.53	4.58	3.79	3.26	4.26	3.53	3.05	4.01	3.32	2.86
	dbA	15	15	15	15	15	15	15	15	15	15	15	15	15	15	15
400	Vel	2.64	2.93	3.70	2.17	2.41	3.05	1.85	2.05	2.59	1.60	1.78	2.25	1.43	1.58	1.99
	P	0.42	0.51	0.82	0.28	0.35	0.56	0.20	0.25	0.40	0.15	0.19	0.30	0.13	0.15	0.24
	T	7.29	6.05	5.19	6.61	5.48	4.72	6.10	5.05	4.35	5.68	4.71	4.05	5.35	4.43	3.82
	dbA	18	19	22	15	16	20	15	15	17	15	15	15	15	15	15
500	Vel	3.29	3.66	4.63	2.71	3.01	3.81	2.30	2.56	3.25	2.00	2.23	2.81	1.77	1.98	2.48
	P	0.65	0.80	1.28	0.44	0.55	0.87	0.32	0.39	0.63	0.25	0.30	0.47	0.19	0.23	0.38
	T	9.11	7.55	6.49	8.28	6.85	5.89	7.63	6.31	5.42	7.11	5.88	5.06	6.68	5.53	4.76
	dbA	22	24	27	19	21	24	17	18	22	15	16	20	15	15	18
600	Vel	3.95	4.39	5.5	3.35	3.62	4.57	2.77	3.07	3.88	2.40	2.67	3.38	2.13	2.36	2.99
	P	0.95	1.16	1.85	0.64	0.78	1.25	0.46	0.57	0.90	0.35	0.43	0.68	0.27	0.34	0.53
	T	10.93	9.05	7.79	9.92	8.21	7.07	9.15	7.57	6.51	8.53	7.06	6.08	8.02	6.65	5.71
	dbA	26	28	31	23	25	28	21	22	26	18	20	24	16	18	22
700	Vel	4.61	5.13	6.48	3.80	4.22	5.33	3.23	3.59	4.53	2.81	3.12	3.95	2.48	2.76	3.48
	P	1.28	1.58	2.52	0.86	1.07	1.71	0.62	0.77	1.23	0.47	0.58	0.93	0.38	0.46	0.73
	T	12.76	10.56	9.09	11.58	9.58	8.25	10.67	8.83	7.60	9.95	8.25	7.09	9.36	7.75	6.66
	dbA	30	31	34	37	28	32	24	26	29	21	23	27	19	21	25
800	Vel	5.27	5.86	7.40	4.34	4.82	6.09	3.69	4.10	5.18	3.21	3.56	4.50	2.83	3.15	3.98
	P	1.67	2.06	3.29	1.13	1.40	2.23	0.82	1.01	1.61	0.62	0.76	1.22	0.48	0.60	0.95
	T	14.58	12.07	10.38	13.23	10.95	9.42	12.19	1.10	8.69	11.38	9.41	8.10	10.69	8.85	7.62
	dbA	33	34	37	30	31	35	27	29	32	24	26	30	22	24	28
900	Vel	5.93	6.59	8.33	4.88	5.43	6.85	4.15	4.61	5.82	3.61	4.01	5.06	3.19	3.54	4.48
	P	2.11	2.61	4.16	1.43	1.77	2.82	1.03	1.27	2.05	0.78	0.96	1.55	0.61	0.75	1.20
	T	16.40	13.58	11.68	14.88	12.32	10.60	13.72	11.36	9.77	12.79	10.59	9.11	12.03	9.96	8.57
	dbA	35	37	40	32	34	37	30	31	35	27	29	33	25	27	31
1000	Vel	6.59	7.32	9.25	5.42	6.03	7.62	4.61	5.12	6.48	4.01	4.45	5.63	3.55	3.95	4.98
	P	2.60	3.22	5.13	1.76	2.18	3.48	1.28	1.58	2.51	0.96	1.19	1.90	0.75	0.93	1.49
	T	18.22	15.09	12.98	16.54	13.69	11.78	15.24	12.62	10.86	14.21	11.77	10.12	13.37	11.07	9.52
	dbA	38	39	42	35	36	40	32	34	37	30	31	35	27	29	33
1200	Vel	7.91	8.79	11.10	6.51	7.23	9.14	5.53	6.15	7.77	4.81	5.34	6.75	4.25	4.73	5.98
	P	3.75	4.63	7.40	2.55	3.14	5.01	1.83	2.27	3.62	1.39	1.71	2.74	1.08	1.34	2.15
	T	21.87	18.11	15.58	19.84	16.43	14.13	18.29	15.14	13.03	17.05	14.12	12.15	16.04	13.28	11.42
	dbA	42	43	46	39	41	44	36	38	42	34	36	40	32	34	38

LxH	300x	200			250			300			350			400		
M3/H	Deflection.	0	22.5	45	0	22.5	45	0	22.5	45	0	22.5	45	0	22.5	45
100	Vel	0.45	0.50	0.63	0.38	0.42	0.53	0.33	0.37	0.46	0.29	0.32	0.41	0.26	0.29	0.37
	P	0.01	0.01	0.02	0.01	0.02	0.02	0.01	0.01	0.01	0.01	0.01	0.01	0.01	0.01	0.01
	T	1.50	1.24	1.07	1.38	1.14	0.99	1.29	1.07	0.92	1.21	1.00	0.86	1.15	0.95	0.82
	dbA	15	15	15	15	15	15	15	15	15	15	15	15	15	15	15
200	Vel	0.89	0.99	1.25	0.76	0.84	1.07	0.66	0.73	0.93	0.58	0.65	0.82	0.52	0.58	0.73
	P	0.05	0.06	0.09	0.03	0.04	0.07	0.03	0.03	0.05	0.02	0.03	0.04	0.02	0.02	0.03
	T	3.00	2.48	2.14	2.77	2.29	1.97	2.58	2.14	1.84	2.43	2.01	1.73	2.30	1.90	1.64
	dbA	15	15	15	15	15	15	15	15	15	15	15	15	15	15	15
300	Vel	1.34	1.49	1.88	1.14	1.26	1.60	0.99	1.10	1.39	0.88	0.97	1.23	0.78	0.87	1.10
	P	0.11	0.13	0.21	0.08	0.10	0.15	0.06	0.07	0.13	0.05	0.06	0.09	0.04	0.05	0.07
	T	4.50	3.73	3.21	4.15	3.43	2.96	3.87	3.20	2.76	3.64	3.01	2.59	3.44	2.85	2.45
	dbA	15	15	15	15	15	15	15	15	15	15	15	15	15	15	15
400	Vel	1.79	1.98	2.51	1.52	1.69	2.13	1.32	1.47	1.85	1.17	1.30	1.64	1.05	1.16	1.47
	P	0.19	0.24	0.38	0.14	0.17	0.27	0.10	0.13	0.21	0.08	0.10	0.16	0.07	0.08	0.13
	T	6.00	4.97	4.27	5.53	4.58	3.94	5.16	4.27	3.67	4.85	4.02	3.46	4.59	3.80	3.27
	dbA	15	15	17	15	15	15	15	15	15	15	15	15	15	15	15
500	Vel	2.23	2.48	3.13	1.90	2.11	2.66	1.65	1.83	2.32	1.46	1.62	2.05	1.31	1.45	1.84
	P	0.30	0.37	0.59	0.22	0.27	0.43	0.16	0.20	0.32	0.13	0.16	0.25	0.10	0.13	0.20
	T	7.50	6.21	5.34	6.91	5.72	4.93	6.45	5.34	4.59	6.06	5.02	4.32	5.74	4.75	4.09
	dbA	16	18	22	15	15	19	15	15	17	15	15	15	15	15	15
600	Vel	2.68	2.98	3.36	2.28	2.53	3.20	1.98	2.20	2.78	1.75	1.95	2.46	1.57	1.74	2.20
	P	0.43	0.53	0.85	0.31	0.38	0.61	0.23	0.29	0.46	0.18	0.23	0.36	0.15	0.18	0.29
	T	9.00	7.45	6.41	8.30	6.87	5.91	7.74	6.41	5.51	7.28	6.02	5.18	6.89	5.70	4.91
	dbA	20	22	25	17	19	23	15	16	21	15	15	18	15	15	16
700	Vel	3.31	3.47	4.39	2.66	2.95	3.73	2.31	2.57	3.24	2.04	2.27	2.87	1.83	2.03	2.57
	P	0.59	0.72	1.16	0.42	0.52	0.83	0.32	0.40	0.63	0.25	0.31	0.49	0.20	0.25	0.40
	T	10.50	8.69	7.48	9.68	8.01	6.90	9.03	7.47	6.43	8.49	7.03	6.05	8.04	6.65	5.74
	dbA	23	25	29	20	22	26	18	20	24	15	17	22	15	15	20
800	Vel	3.57	3.97	5.02	3.03	3.37	4.06	2.63	2.93	3.71	2.33	2.59	3.28	2.09	2.33	2.94
	P	0.77	0.95	1.15	0.55	0.68	1.09	0.42	0.52	0.82	0.33	0.40	0.64	0.26	0.32	0.52
	T	12	9.94	8.55	11.06	9.16	7.88	10.32	8.54	7.35	9.70	8.03	6.91	9.19	7.60	6.54
	dbA	26	28	32	23	25	29	21	23	27	18	20	25	16	18	23
900	Vel	4.02	4.47	5.64	3.41	3.79	4.79	2.97	3.30	4.17	2.63	2.92	3.69	2.35	2.62	3.31
	P	0.97	1.20	1.91	0.70	0.86	1.38	0.53	0.65	1.04	0.41	0.51	0.82	0.33	0.41	0.66
	T	13.50	11.18	9.62	12.45	10.30	8.87	11.61	9.61	8.27	10.91	9.04	7.77	10.33	8.56	7.36
	dbA	29	31	34	26	28	32	23	25	30	21	23	28	18	21	26
1000	Vel	4.46	4.96	6.27	3.79	4.22	5.33	3.30	3.67	4.63	2.92	3.24	4.10	2.61	2.91	3.67
	P	1.20	1.48	2.36	0.86	1.07	1.70	0.65	0.81	1.29	0.51	0.63	1.01	0.41	0.51	0.81
	T	15.00	12.42	10.69	13.83	11.45	9.85	12.89	10.68	9.18	12.10	10.04	8.64	11.48	9.51	8.18
	dbA	32	33	37	29	31	34	26	28	32	23	26	30	21	23	28
1200	Vel	5.36	5.95	7.52	4.55	5.06	6.39	3.96	4.40	5.56	3.50	3.89	4.92	3.14	3.49	4.41
	P	1.72	2.13	3.40	1.24	1.54	2.45	0.94	1.16	1.85	0.74	0.91	1.45	0.59	0.73	1.17
	T	18.00	14.90	12.82	16.60	13.74	11.82	15.47	12.81	11.02	14.55	12.05	10.37	13.78	11.41	9.81
	dbA	36	38	41	33	35	39	30	32	36	28	30	34	25	28	32



- * They are used as a supply grille
- * Their blades are adjustable horizontally and vertically.
- * Accessories: Damper, Plenum box
- * Mounting: Screw fixing is standard, concealed clip fixing as optional.
- * Finishing: White powder coating Ra19016, Ra19010, or customized color. Anodized.

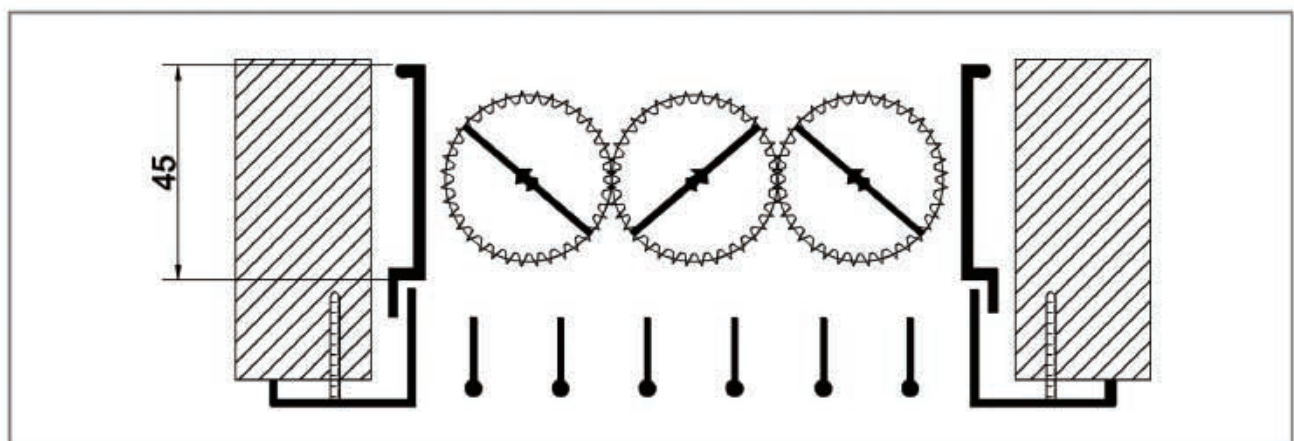
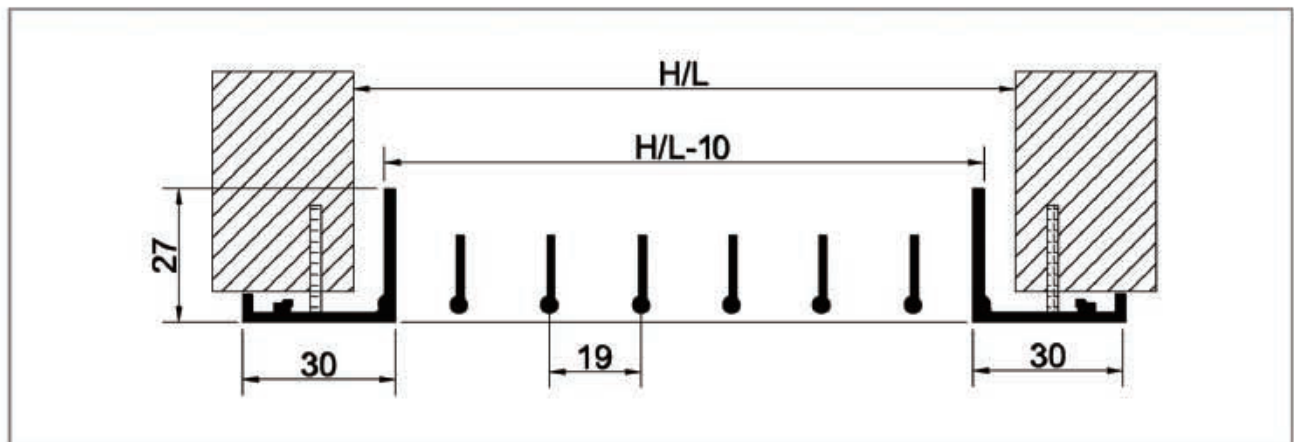

LxH	100x	200			250			300			350			400		
M3/H	Deflection.	0	22.5	45	0	22.5	45	0	22.5	45	0	22.5	45	0	22.5	45
100	Vel	2.16	2.37	3.16	1.70	1.86	2.48	1.40	1.53	2.05	1.18	1.29	1.73	1.03	1.13	1.51
	P	0.28	0.34	0.60	0.17	0.22	0.37	0.12	0.14	0.25	0.08	0.10	0.18	0.06	0.08	0.14
	T	2.70	2.22	1.96	2.39	1.97	1.73	2.17	1.79	1.58	2.00	1.65	1.46	1.86	1.53	1.36
	dbA	15	15	15	15	15	15	15	15	15	15	15	15	15	15	15
200	Vel	4.32	4.75	6.33	3.39	3.73	4.97	2.79	3.08	4.10	2.37	2.61	3.48	2.06	2.28	3.02
	P	1.12	1.35	2.40	0.69	0.83	1.48	0.48	0.58	1.00	0.34	0.41	0.72	0.26	0.31	0.55
	T	5.40	4.44	3.93	4.78	3.94	3.48	4.34	3.57	3.16	4.00	3.29	2.91	3.73	3.07	2.71
	dbA	17	18	20	15	16	18	15	15	17	15	15	15	15	15	15
300	Vel	6.48	7.12	9.49	5.09	5.59	7.45	4.19	4.60	6.13	3.55	3.91	5.21	3.09	3.40	4.53
	P	2.52	3.04	5.41	1.55	1.88	3.33	1.05	1.38	2.26	0.76	0.92	1.63	0.58	0.69	1.23
	T	8.10	6.68	5.89	7.17	5.91	5.22	6.51	5.36	4.73	6.00	4.93	4.37	5.59	4.61	4.08
	dbA	25	25	27	23	23	26	21	22	24	19	20	23	18	19	22
400	Vel	8.64	9.50	12.66	6.78	7.46	9.94	5.58	6.13	8.18	4.73	5.22	6.95	4.12	4.53	6.03
	P	4.48	5.41	9.61	2.76	3.33	5.93	1.88	2.26	4.02	1.35	1.63	2.90	1.02	1.23	2.19
	T	10.80	8.89	7.85	9.57	7.88	6.96	8.68	7.15	6.32	8.00	6.59	5.82	7.46	6.14	5.43
	dbA	30	31	33	38	29	31	27	27	30	25	26	29	23	24	27
500	Vel	10.80	11.87	15.82	8.48	9.32	12.42	6.98	7.66	10.23	5.93	6.51	8.70	5.15	5.66	7.56
	P	6.99	8.46	15.02	4.31	5.21	9.26	2.92	3.53	6.28	2.11	2.55	4.53	1.59	1.93	3.42
	T	13.49	11.11	9.82	11.96	9.85	8.70	10.85	8.93	7.89	10.00	8.23	7.28	9.32	7.68	6.78
	dbA	35	36	38	33	34	36	31	32	35	29	30	33	28	29	32
600	Vel	12.95	14.25	18.99	10.17	11.19	14.91	8.38	9.21	12.28	7.12	7.82	10.43	6.19	6.80	9.08
	P	10.08	12.18	21.63	6.31	7.51	13.33	4.21	5.06	9.03	3.05	3.68	6.53	2.21	2.78	4.94
	T	16.19	13.33	11.79	14.36	11.83	10.45	13.02	10.73	9.48	12.01	9.89	8.74	11.20	9.22	8.15
	dbA	39	40	42	37	38	40	35	36	38	33	34	37	32	33	36
700	Vel	15.11	16.62	22.15	11.88	13.06	17.39	9.77	10.75	14.32	8.31	9.13	12.17	7.22	9.95	10.58
	P	13.72	16.58	29.45	8.46	10.22	18.15	5.74	6.92	12.31	4.15	5.01	8.88	3.13	3.79	6.72
	T	18.89	15.56	13.75	16.75	13.79	12.18	15.19	12.51	11.05	14.00	11.53	10.19	13.05	10.75	9.50
	dbA	42	43	45	40	41	43	38	39	42	37	38	40	35	36	39
800	Vel	17.27	18.99	25.31	13.58	14.91	19.88	11.18	12.28	16.36	9.49	10.44	13.90	8.25	9.08	12.10
	P	17.90	21.65	38.45	11.04	13.36	23.72	7.48	9.05	16.06	5.41	6.53	11.61	4.08	4.95	8.77
	T	21.59	17.78	15.72	19.13	15.75	13.92	17.36	14.29	12.63	16.01	13.18	11.65	14.92	12.30	10.86
	dbA	45	46	48	43	44	46	41	42	45	40	41	43	38	39	42
900	Vel										10.67	11.74	15.65	9.28	10.21	13.61
	P										6.85	8.28	14.68	5.18	6.25	11.11
	T										18.01	14.82	13.11	16.78	13.82	12.22
	dbA										42	43	46	41	42	45
1000	Vel										11.86	13.05	17.38	10.32	11.35	15.12
	P										8.44	10.19	18.11	6.38	7.71	13.59
	T										20.10	16.58	14.55	18.66	15.38	13.58
	dbA										45	46	49	43	44	47

LxH		150x			200			250			300			350			400		
M3/H	Deflection.	0	22.5	45	0	22.5	45	0	22.5	45	0	22.5	45	0	22.5	45			
100	Vel	1.35	1.48	1.98	1.06	1.16	1.55	0.88	0.96	1.28	0.75	0.82	1.08	0.65	0.71	0.95			
	P	0.11	0.13	0.23	0.08	0.09	0.14	0.05	0.05	0.10	0.03	0.04	0.06	0.02	0.03	0.05			
	T	2.13	1.76	1.55	1.89	1.56	1.38	1.72	1.42	1.25	1.58	1.31	1.15	1.48	1.22	1.08			
	dbA	15	15	15	15	15	15	15	15	15	15	15	15	15	15	15			
200	Vel	2.69	2.96	3.95	2.11	2.32	3.10	1.75	1.91	2.55	1.49	1.63	2.18	1.39	1.41	1.88			
	P	0.43	0.53	0.93	0.27	0.32	0.58	0.18	0.22	0.39	0.13	0.16	0.28	0.10	0.12	0.22			
	T	4.26	3.52	3.10	3.78	3.11	2.75	3.43	2.82	2.49	3.16	2.61	2.30	2.95	2.44	2.15			
	dbA	15	15	16	15	15	15	15	15	15	15	15	15	15	15	15			
300	Vel	4.04	4.45	5.93	3.18	3.49	4.65	3.62	2.88	3.83	2.22	2.45	3.25	1.93	2.12	2.84			
	P	0.98	1.18	2.11	0.61	0.73	1.30	0.42	0.49	0.88	0.30	0.36	0.63	0.22	0.28	0.48			
	T	6.39	5.26	4.65	5.68	4.68	4.12	5.15	4.23	3.75	4.75	3.90	3.45	4.42	3.65	3.22			
	dbA	20	21	24	18	19	22	16	17	20	15	15	18	15	15	17			
400	Vel	5.38	5.92	7.89	4.23	4.65	6.20	3.48	3.83	5.10	2.96	3.25	4.33	2.57	2.83	3.77			
	P	1.74	2.10	3.74	1.07	1.30	2.30	0.73	0.88	1.55	0.52	0.63	1.13	0.41	0.49	0.85			
	T	8.52	7.02	6.20	7.55	6.22	5.50	6.85	5.63	4.99	6.32	5.20	4.60	5.89	4.85	4.29			
	dbA	8.52	27	30	24	25	28	21	22	26	19	20	24	17	19	22			
500	Vel	6.73	7.40	9.86	5.29	5.81	7.75	4.35	4.78	6.38	3.70	4.07	5.42	3.21	3.53	4.71			
	P	2.72	3.29	5.83	1.68	2.03	3.60	1.14	1.38	2.44	0.82	0.99	1.76	0.62	0.75	1.33			
	T	10.65	8.77	7.75	9.44	7.78	6.87	8.57	7.05	6.23	7.90	6.50	5.75	7.36	6.06	5.36			
	dbA	31	32	34	28	29	32	26	27	30	24	25	29	22	23	27			
600	Vel	8.08	8.88	11.83	6.33	6.98	9.29	5.22	5.75	7.65	4.44	4.88	6.50	3.86	4.24	5.65			
	P	3.91	4.73	8.41	2.41	2.92	5.18	1.64	1.98	3.51	1.18	1.43	2.54	0.89	1.08	1.92			
	T	12.79	10.53	9.30	11.33	9.33	8.24	10.28	8.47	7.48	9.48	7.80	6.89	8.85	7.28	6.43			
	dbA	35	36	38	32	33	36	30	31	34	28	29	32	26	27	31			
700	Vel	9.42	10.36	13.81	7.40	8.14	10.84	6.09	6.70	8.93	5.18	5.69	7.59	4.50	4.95	6.59			
	P	5.33	6.44	11.44	3.29	3.97	7.06	2.23	2.69	4.78	1.61	1.94	3.45	1.21	1.47	2.61			
	T	14.92	12.28	10.85	13.22	10.89	9.62	11.99	9.88	8.73	11.06	9.10	8.04	10.31	8.49	7.50			
	dbA	38	39	42	36	37	39	33	34	38	31	32	36	29	30	34			
800	Vel	10.77	11.85	15.78	8.46	9.30	12.39	6.96	7.65	10.20	5.92	6.50	8.67	5.14	5.66	7.54			
	P	6.96	14.04	14.95	4.29	5.19	9.22	2.91	3.52	6.24	2.10	2.54	4.51	1.59	1.92	3.41			
	T	17.05	13.30	12.40	15.11	12.44	10.99	13.71	11.29	9.98	12.63	10.40	9.19	11.78	9.70	8.57			
	dbA	41	42	45	39	40	42	36	37	41	34	35	39	32	33	37			
900	Vel	12.12	10.65	17.76	9.51	10.46	13.94	7.83	8.61	11.48	6.65	7.32	9.75	5.79	6.36	8.48			
	P	8.81	15.79	18.92	5.43	6.57	11.66	3.68	4.45	7.90	2.66	3.21	5.71	2.01	2.43	4.31			
	T	19.18	15.21	13.95	17.00	14.01	12.37	15.42	12.70	11.22	14.21	11.71	10.34	13.25	10.91	9.64			
	dbA	44	45	47	41	42	45	39	40	43	37	38	41	35	36	40			
1000	Vel	13.46	14.86	19.73	10.57	11.62	15.49	8.70	9.68	12.75	7.39	8.13	10.83	6.43	7.07	9.42			
	P	10.87	13.15	23.35	6.70	8.11	14.40	4.45	5.49	9.76	3.28	3.97	7.05	2.48	3.00	5.33			
	T	21.31	17.55	15.51	18.88	15.55	13.74	17.13	14.11	12.47	15.79	13.01	11.49	14.73	12.13	10.71			
	dbA	46	47	50	44	45	48	41	43	46	39	41	44	37	39	42			
1200	Vel										8.87	9.76	13.00	7.71	8.48	11.31			
	P										4.72	5.71	10.15	3.57	4.32	7.67			
	T										18.95	15.61	13.79	17.67	14.55	12.86			
	dbA										44	45	48	42	43	47			

LxH	200x	200			250			300			350			400		
M3/H	Deflection.	0	22.5	45	0	22.5	45	0	22.5	45	0	22.5	45	0	22.5	45
100	Vel	0.98	1.08	1.43	0.77	0.84	1.13	0.63	0.70	0.93	0.55	0.59	0.79	0.47	0.51	0.68
	P	0.06	0.07	0.12	0.04	0.04	0.08	0.02	0.03	0.05	0.02	0.02	0.04	0.01	0.02	0.03
	T	1.82	1.50	1.32	1.61	1.33	1.17	1.46	1.20	1.06	1.35	1.11	0.98	1.26	1.03	0.91
	dbA	15	15	15	15	15	15	15	15	15	15	15	15	15	15	15
200	Vel	1.96	2.15	2.87	1.54	1.69	2.25	1.26	1.39	1.85	1.07	1.18	1.57	0.93	1.03	1.37
	P	0.23	0.28	0.49	0.14	0.17	0.30	0.10	0.12	0.21	0.07	0.08	0.15	0.05	0.06	0.11
	T	3.63	2.99	2.64	3.22	2.65	2.34	2.92	2.41	2.13	2.69	2.22	1.96	2.51	2.07	1.83
	dbA	15	15	15	15	15	15	15	15	15	15	15	15	15	15	15
300	Vel	2.93	3.23	4.30	2.30	2.53	3.38	1.90	2.09	2.78	1.61	1.77	2.36	1.40	1.54	2.05
	P	0.52	0.62	1.11	0.32	0.39	0.68	0.22	0.26	0.46	0.16	0.19	0.33	0.12	0.14	0.25
	T	5.45	4.49	3.96	4.83	3.98	3.51	4.38	3.61	3.19	4.04	3.33	2.94	3.77	3.10	2.74
	dbA	17	18	21	15	15	19	15	15	16	15	15	15	15	15	15
400	Vel	3.91	4.30	5.73	3.07	3.38	4.50	2.53	2.78	3.71	2.15	2.36	3.15	1.87	2.05	2.74
	P	0.92	1.11	1.97	0.57	0.68	1.22	0.38	0.46	0.82	0.28	0.33	0.59	0.21	0.25	0.45
	T	7.27	5.98	5.29	6.44	5.30	4.68	5.84	4.81	4.25	5.38	4.43	3.92	5.02	4.13	3.65
	dbA	23	24	27	20	21	24	17	18	22	15	16	20	15	15	18
500	Vel	4.89	5.38	7.17	3.84	4.22	5.63	3.16	3.48	4.63	2.69	2.95	3.94	2.34	2.57	3.42
	P	1.43	1.73	3.08	0.88	1.07	1.90	0.60	0.72	1.29	0.43	0.52	0.93	0.33	0.40	0.70
	T	9.08	7.48	6.61	8.05	6.63	5.86	7.30	6.01	5.31	6.73	5.54	4.90	6.28	5.17	4.57
	dbA	27	28	31	24	26	29	12	23	27	19	21	25	17	18	23
600	Vel	5.87	6.45	8.60	4.61	5.07	6.75	3.79	4.17	5.56	3.22	3.54	4.72	2.80	3.08	4.11
	P	2.07	2.50	4.44	1.27	1.54	2.74	0.86	1.04	1.85	0.62	0.75	1.34	0.47	0.57	1.01
	T	10.90	8.97	7.93	9.66	7.95	7.03	8.76	7.22	6.38	8.08	6.65	5.88	7.53	6.20	5.48
	dbA	31	32	35	28	29	33	26	27	31	23	25	29	21	22	27
700	Vel	6.85	7.53	10.03	5.38	5.91	7.88	4.43	4.87	6.49	3.76	4.13	5.51	3.27	3.59	4.79
	P	2.81	3.40	6.04	1.73	2.10	3.72	1.17	1.42	5.52	0.85	1.03	1.82	0.64	0.78	1.38
	T	12.71	10.47	9.25	11.27	9.28	8.20	10.22	8.42	7.44	9.42	7.76	6.86	8.79	7.24	6.39
	dbA	35	36	39	32	33	36	29	30	34	26	28	32	24	26	30
800	Vel	7.82	8.60	11.47	6.14	6.76	9.00	5.06	5.56	7.41	4.30	4.73	6.30	3.74	4.11	5.48
	P	3.67	4.44	7.89	2.26	2.74	4.86	1.53	1.86	3.30	1.11	1.34	2.38	0.84	1.01	1.80
	T	14.53	11.97	10.57	12.88	10.60	9.37	11.68	9.62	8.50	10.77	8.87	7.84	10.04	8.27	7.31
	dbA	38	39	42	35	36	39	32	33	37	29	31	35	27	29	33
900	Vel	8.80	9.68	12.90	6.91	7.60	10.13	5.69	6.26	8.34	4.83	5.32	7.09	4.20	4.62	6.16
	P	4.65	5.62	9.98	2.87	3.48	6.16	1.94	2.35	4.18	1.41	1.70	3.02	1.06	1.28	2.28
	T	16.35	13.46	11.89	14.49	11.93	10.54	13.14	10.82	9.56	12.12	9.98	8.82	11.30	9.30	8.22
	dbA	40	41	44	37	39	42	35	36	40	32	34	38	30	31	36
1000	Vel	9.78	10.75	14.33	7.68	8.44	11.25	6.32	6.95	9.26	5.37	5.91	7.87	4.67	5.14	6.85
	P	5.74	6.95	12.32	3.55	4.28	7.60	2.40	2.90	5.15	1.73	2.09	7.87	1.31	1.58	2.81
	T	18.16	14.96	13.22	16.09	13.25	11.71	4.60	12.03	10.63	13.46	11.09	9.79	12.55	10.34	9.13
	dbA	43	44	47	40	41	44	37	38	42	35	36	40	32	34	38
1200	Vel				9.22	10.13	13.50	7.59	8.35	11.12	6.45	7.09	9.45	5.60	6.16	8.21
	P				5.10	6.16	10.95	3.45	4.17	7.42	2.49	3.01	5.35	1.88	2.28	4.05
	T				19.31	15.90	14.05	17.52	14.43	12.75	16.15	13.30	11.75	15.06	12.40	10.96
	dbA				44	45	49	41	43	45	39	40	44	37	38	43

LxH	250x	200			250			300			350			400		
M3/H	Deflection.	0	22.5	45	0	22.5	45	0	22.5	45	0	22.5	45	0	22.5	45
100	Vel	0.60	0.66	0.88	0.50	0.55	0.73	0.42	0.46	0.62	0.37	0.40	0.54	0.32	0.36	0.48
	P	0.02	0.03	0.05	0.01	0.02	0.03	0.01	0.01	0.02	0.01	0.01	0.02	0.01	0.01	0.01
	T	1.43	1.17	1.04	1.29	1.07	0.94	1.19	0.98	0.87	1.11	0.92	0.81	1.05	0.86	0.76
	dbA	15	15	15	15	15	15	15	15	15	15	15	15	15	15	15
200	Vel	1.21	1.33	1.77	0.99	1.09	1.45	0.84	0.93	1.24	0.73	0.81	1.07	0.65	0.71	0.95
	P	0.09	0.11	0.19	0.06	0.07	0.13	0.04	0.05	0.09	0.03	0.04	0.07	0.03	0.03	0.05
	T	2.85	2.35	2.98	2.59	2.13	1.88	2.39	1.96	1.74	2.22	1.83	1.62	2.09	1.72	1.52
	dbA	15	15	15	15	15	15	15	15	15	15	15	15	15	15	15
300	Vel	1.81	1.99	2.65	1.49	1.64	2.18	1.27	1.39	1.85	1.10	1.21	1.61	0.97	1.07	1.43
	P	0.20	0.24	0.42	0.13	0.16	0.29	0.10	0.12	0.21	0.07	0.09	0.16	0.06	0.07	0.12
	T	4.28	3.52	3.11	3.88	3.20	2.82	3.58	2.95	2.60	3.34	2.75	2.43	3.14	2.58	2.28
	dbA	15	15	16	15	15	15	15	15	15	15	15	15	15	15	15
400	Vel	2.41	2.65	3.53	1.99	2.18	2.91	1.69	1.86	2.47	1.47	1.61	2.15	1.30	1.43	1.90
	P	0.35	0.42	0.75	0.24	0.29	0.51	0.17	0.21	0.37	0.13	0.16	0.28	0.10	0.12	0.22
	T	5.70	4.70	4.15	5.18	4.26	3.77	4.77	3.93	3.47	4.45	3.66	3.24	4.18	3.45	3.04
	dbA	16	18	21	15	15	19	15	15	17	15	15	15	15	15	15
500	Vel	3.01	3.32	4.42	2.48	2.73	3.64	2.11	2.32	3.09	1.83	2.02	2.69	1.62	1.78	2.38
	P	0.55	0.66	1.17	0.37	0.45	0.79	0.27	0.32	0.57	0.20	0.24	0.43	0.16	0.19	0.34
	T	7.13	5.87	5.19	6.47	5.33	4.71	5.96	4.91	4.34	5.56	4.58	4.05	5.23	4.31	3.81
	dbA	21	22	26	18	19	24	15	17	21	15	15	19	15	15	17
600	Vel	3.62	3.98	5.30	2.98	3.27	4.36	2.53	2.78	3.71	2.20	2.42	3.22	1.95	2.14	2.85
	P	0.79	0.95	1.69	0.53	0.64	1.14	0.38	0.46	0.83	0.29	0.35	0.62	0.23	0.27	0.49
	T	8.56	7.05	6.23	7.76	6.39	5.65	7.16	5.89	5.21	6.67	5.50	4.86	6.28	5.17	4.57
	dbA	25	26	30	22	23	28	19	21	25	16	18	23	15	16	21
700	Vel	4.22	6.64	6.19	3.47	3.82	5.09	2.95	3.25	4.33	2.57	2.82	3.76	2.27	2.50	3.33
	P	1.07	1.29	2.30	0.72	0.88	1.56	0.52	0.63	1.12	0.40	0.48	0.85	0.31	0.37	0.66
	T	9.98	8.22	7.26	9.06	7.46	6.59	8.35	6.88	6.08	7.79	6.41	5.66	7.32	6.03	5.33
	dbA	28	30	33	25	27	31	22	24	29	20	22	26	17	19	24
800	Vel	4.82	5.30	7.07	3.97	4.37	5.82	3.37	3.71	4.95	2.93	3.23	4.30	2.59	2.85	3.80
	P	1.40	1.69	3.00	0.95	1.14	2.03	0.68	0.83	1.47	0.52	0.62	1.11	0.40	0.49	0.87
	T	11.41	9.40	8.30	10.35	8.52	7.53	9.54	7.87	6.94	8.90	7.33	6.47	8.37	6.89	6.09
	dbA	31	33	36	28	30	34	25	27	32	23	25	29	20	22	27
900	Vel	5.43	5.97	7.95	4.47	4.91	6.55	3.80	4.17	5.56	3.30	3.63	4.84	2.92	3.21	4.28
	P	1.77	2.14	3.80	1.20	1.45	2.57	0.86	1.05	1.86	0.65	0.79	1.40	0.51	0.62	1.10
	T	12.84	10.57	9.34	11.65	9.95	8.47	10.74	8.84	7.81	10.01	8.24	7.28	9.41	7.75	6.85
	dbA	34	35	39	31	32	37	28	30	34	25	27	32	23	25	30
1000	Vel	6.03	6.63	8.84	4.96	5.46	7.27	4.22	4.64	6.18	3.67	4.03	5.37	3.24	3.57	4.75
	P	2.18	2.64	4.69	1.48	1.79	3.18	1.07	1.29	2.29	0.81	0.98	1.73	0.63	0.76	1.36
	T	14.26	11.74	10.38	12.94	10.66	9.42	11.93	9.82	6.68	11.12	9.16	8.09	10.56	8.61	7.61
	dbA	36	38	42	33	35	39	31	32	37	28	30	35	26	27	33
1200	Vel	7.24	7.96	10.60	5.96	6.55	8.73	5.06	5.57	7.42	4.40	4.84	6.45	3.89	4.28	5.70
	P	3.14	3.80	6.75	2.13	2.57	4.57	1.54	1.86	3.30	1.16	1.40	2.50	0.91	1.10	1.95
	T	17.11	14.09	12.45	15.53	12.79	11.30	14.31	11.79	10.42	13.35	10.99	9.71	12.55	10.34	9.13
	dbA	41	42	46	38	39	43	35	37	41	32	34	39	30	32	37

LxH	300x	200			250			300			350			400		
M3/H	Deflection.	0	22.5	45	0	22.5	45	0	22.5	45	0	22.5	45	0	22.5	45
100	Vel	0.41	0.45	0.60	0.35	0.38	0.51	0.30	0.33	0.44	0.27	0.29	0.39	0.24	0.26	0.35
	P	0.01	0.01	0.02	0.01	0.01	0.02	0.01	0.01	0.01		0.01	0.01			0.01
	T	1.17	0.97	0.85	1.08	0.89	0.79	1.01	0.83	0.73	0.95	0.78	0.69	0.90	0.74	0.65
	dbA	15	15	15	15	15	15	15	15	15	15	15	15	15	15	15
200	Vel	0.82	0.90	1.20	0.69	0.76	1.02	0.60	0.66	0.88	0.53	0.59	0.78	0.48	0.53	0.70
	P	0.04	0.05	0.09	0.03	0.03	0.06	0.02	0.03	0.05	0.02	0.02	0.04	0.01	0.02	0.03
	T	2.35	1.93	1.71	2.16	1.78	1.57	2.02	1.66	1.47	1.90	1.56	1.38	1.80	1.48	1.31
	dbA	15	15	15	15	15	15	15	15	15	15	15	15	15	15	15
300	Vel	1.23	1.35	1.80	1.04	1.15	1.53	0.91	1.00	1.33	0.80	0.88	1.17	0.72	0.79	1.05
	P	0.09	0.11	0.19	0.07	0.08	0.14	0.05	0.06	0.11	0.04	0.05	0.08	0.03	0.04	0.07
	T	3.52	2.90	2.56	3.25	2.67	2.36	3.03	2.49	2.20	2.85	2.34	2.07	2.70	2.22	1.96
	dbA	15	15	15	15	15	15	15	15	15	15	15	15	15	15	15
400	Vel	1.63	1.80	2.40	1.39	1.53	2.04	1.21	1.33	1.77	1.07	1.17	1.57	0.96	1.05	1.40
	P	0.16	0.19	0.34	0.12	0.14	0.25	0.09	0.11	0.19	0.07	0.08	0.15	0.05	0.07	0.12
	T	4.70	3.87	3.42	4.33	3.56	3.15	4.04	3.32	2.94	3.80	3.13	2.76	3.95	2.96	2.62
	dbA	15	15	15	15	15	15	15	15	15	15	15	15	15	15	15
500	Vel	2.04	2.25	2.99	1.74	1.91	2.54	1.51	1.66	2.21	1.34	1.47	1.96	1.20	1.32	1.75
	P	0.25	0.30	0.54	0.18	0.22	0.39	0.14	0.17	0.29	0.11	0.13	0.23	0.09	0.10	0.18
	T	5.87	4.83	4.27	5.41	4.46	3.94	5.05	4.15	3.67	4.75	3.91	3.45	4.49	3.70	3.27
	dbA	15	16	21	15	15	18	15	15	16	15	15	15	15	15	15
600	Vel	2.45	2.70	3.59	2.08	2.29	3.05	1.81	1.99	2.65	1.60	1.76	2.35	1.44	1.58	2.10
	P	0.36	0.44	0.77	0.26	0.31	0.56	0.20	0.24	0.42	0.15	0.19	0.33	0.12	0.15	0.27
	T	7.04	5.80	5.13	6.49	5.35	4.72	6.05	4.99	4.41	5.59	4.69	4.14	5.39	4.44	3.92
	dbA	18	20	24	15	17	22	15	15	20	15	15	18	15	15	16
700	Vel	2.86	3.15	4.19	2.43	2.67	3.56	2.11	2.32	3.10	1.87	2.06	2.74	1.68	1.84	2.46
	P	0.49	0.59	1.05	0.35	0.43	0.76	0.27	0.32	0.58	0.21	0.25	0.45	0.17	0.20	0.36
	T	8.22	6.77	5.98	7.58	6.24	5.51	7.06	5.82	5.14	6.64	5.47	4.83	6.29	5.18	4.58
	dbA	22	23	28	19	21	26	16	18	23	15	15	21	15	15	19
800	Vel	3.27	3.59	4.79	2.78	3.05	4.07	2.42	2.66	3.54	2.14	2.35	3.13	1.91	2.11	2.81
	P	0.64	0.78	1.38	0.46	0.56	0.99	0.35	0.42	0.75	0.27	0.33	0.59	0.22	0.27	0.47
	T	9.39	7.73	6.83	8.66	7.13	6.30	8.07	6.65	5.87	7.59	6.25	5.52	7.19	5.92	5.23
	dbA	25	26	31	22	24	29	19	21	26	16	18	24	15	16	22
900	Vel	3.68	4.04	5.39	3.13	3.44	4.58	2.72	2.99	3.98	2.40	2.64	3.52	2.15	2.37	3.16
	P	0.81	0.98	1.74	0.59	0.71	1.26	0.44	0.54	0.95	0.35	0.42	0.74	0.28	0.34	0.60
	T	10.57	8.70	7.69	9.74	8.02	7.09	9.08	7.48	6.61	8.54	7.03	6.21	8.09	6.66	5.88
	dbA	28	29	34	24	26	31	22	24	29	19	21	27	16	19	25
1000	Vel	4.09	4.49	5.99	3.47	3.82	5.09	3.02	3.32	4.42	2.67	2.94	3.91	2.39	2.63	3.51
	P	1.00	1.21	2.15	0.72	0.87	1.55	0.55	0.66	1.17	0.43	0.52	0.92	0.34	0.42	0.74
	T	11.74	9.67	8.54	10.82	8.91	7.87	10.09	8.31	7.34	9.49	7.82	6.91	8.99	7.40	6.54
	dbA	30	32	36	27	29	34	24	26	31	21	23	29	19	21	27
1200	Vel	4.90	5.39	7.19	4.17	4.58	6.11	3.62	3.98	5.31	3.20	3.52	4.70	2.87	3.16	4.21
	P	1.94	1.74	3.10	1.04	1.26	2.24	0.79	0.95	1.69	0.62	0.74	1.32	0.49	0.60	1.06
	T	14.09	11.60	10.25	12.99	10.68	9.45	12.11	9.98	8.81	11.39	9.38	8.29	10.78	8.88	7.86
	dbA	34	36	41	31	33	38	28	30	36	26	28	33	23	25	31

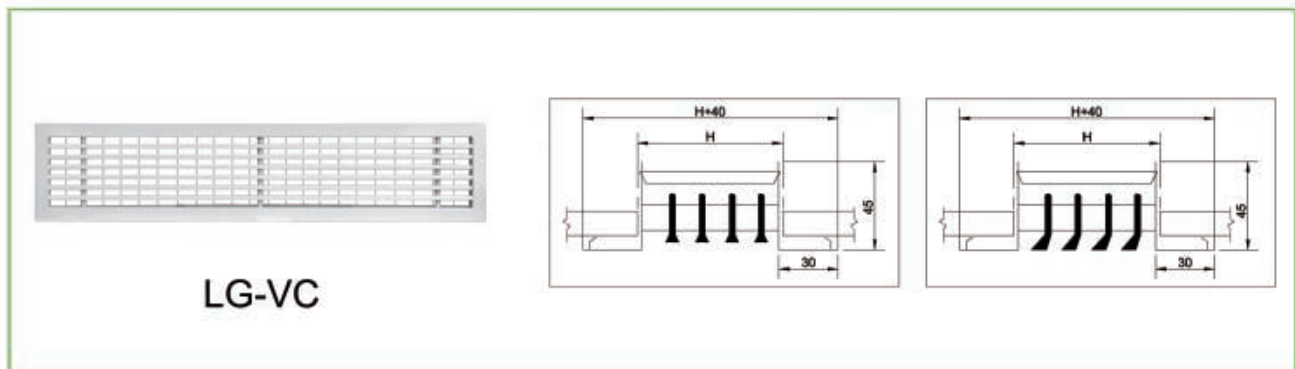
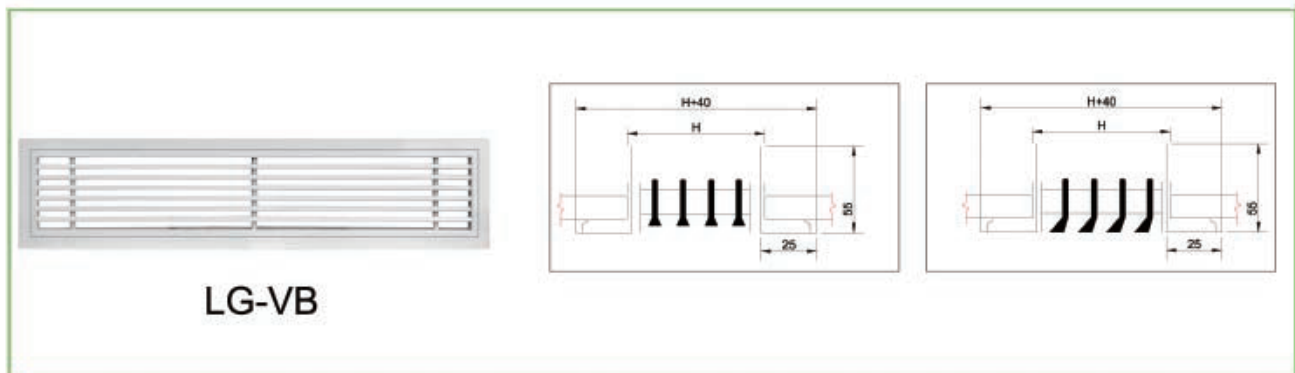
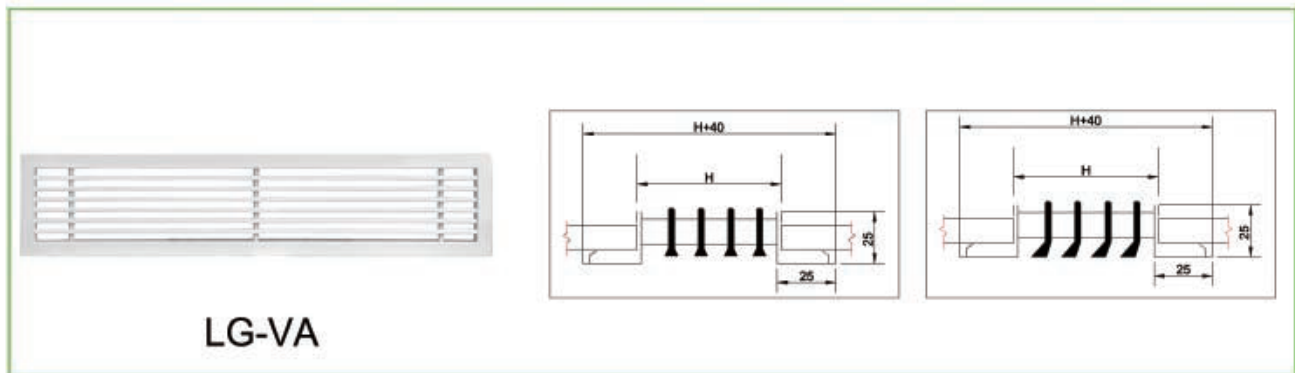

- * They can be used as supply or return grilles.
- * They can be with different width of frames, narrow or wide, to be used at different applications.
- * They get different type of blades: 0°, 15°, 30°
- * Mounting: Screw system is standard, concealed clip fixing as optional.
- * Accessories: opposite blade damper.
- * Finishing: White powder coating Ral9016, Ral9010, or customized color. Anodized.

The data of this table are for 0°.

Regarding 15°, you have to add 10% to the Throw.

And regarding 30°, you have to add 20% to the Throw.

Size(mm)	Velocity(m/s)	2	3	4	5	6	7	8
300x100	M3/H	121	180	241	301	360	422	481
	dbA					30	34	38
	Throw	1.9-2.8	3.2-4.3	4.1-5.6	4.9-7.2	4.8-8.3	6.8-9.9	8.0-11.1
600x100	M3/H	226	338	452	564	677	791	903
	dbA				28	33	37	40
	Throw	2.5-3.5	3.5-4.9	4.7-6.8	5.9-8.3	7.1-10.2	8.0-11.7	9.5-13.5
900x100	M3/H	348	519	692	865	1039	1210	1385
	dbA				30	35	39	42
	Throw	2.8-4.1	4.4-5.9	5.6-7.7	6.8-9.9	7.9-11.7	9.5-13.6	10.8-15.5
1200x100	M3/H	466	700	933	1166	1399	1632	1867
	dbA				31	36	40	43
	Throw	3.2-5.3	4.7-6.5	5.9-8.3	7.4-10.5	8.9-12.6	10.2-14.7	12.0-16.9
1500x100	M3/H	587	881	1173	1467	1761	2055	2348
	dbA				32	37	41	44
	Throw	3.2-4.7	4.7-6.8	6.5-9.2	8.0-11.4	9.5-13.5	11.1-15.9	12.6-18.1
1800x100	M3/H	707	1061	1414	1768	2122	2475	2829
	dbA			27	33	38	42	45
	Throw	4.0-5.1	5.3-7.4	7.1-9.9	8.6-12.3	10.5-14.4	12.0-16.9	13.5-19.3

Size(mm)	Velocity(m/s)	2	3	4	5	6	7	8
300x125	M3/H	141	213	282	354	425	495	566
	dbA					30	34	38
	Throw	2.2-3.2	3.2-4.4	4.1-5.9	5.3-7.4	6.5-8.9	7.0-7.2	8.0-11.7
600x125	M3/H	266	399	531	664	797	929	1062
	dbA				28	3	37	40
	Throw	2.5-3.8	3.8-5.3	5.0-7.1	6.5-8.9	7.7-10.8	8.6-12.3	10.2-14.2
900x125	M3/H	406	610	812	1018	1221	1423	1625
	dbA				30	35	39	42
	Throw	2.8-4.1	4.4-6.2	5.6-7.9	7.1-10.1	8.2-11.9	10.1-14.0	11.4-16.3
1200x125	M3/H	547	823	1098	1370	1644	1918	2193
	dbA				31	36	40	43
	Throw	3.1-4.3	4.6-6.7	6.1-8.8	7.9-11.1	9.5-13.4	10.8-15.5	12.2-17.8
1500x125	M3/H	690	1034	1379	1725	2069	2415	2758
	dbA				32	37	41	44
	Throw	3.4-4.6	4.9-7.0	7.0-9.4	8.3-11.9	10.2-14.1	11.7-16.6	13.5-18.9
1800x125	M3/H	829	1244	1659	2075	2488	2965	3318
	dbA			27	33	38	42	45
	Throw	3.7-5.2	5.5-7.6	7.0-10.2	8.8-12.5	10.7-15.2	12.2-17.8	14.3-20.1

Size(mm)	Velocity(m/s)	2	3	4	5	6	7	8
300x150	M3/H	226	338	452	563	677	791	903
	dbA				27	32	36	40
	Throw	2.4-3.4	3.5-4.9	4.6-6.7	5.8-8.2	7.0-10.1	7.9-11.6	9.2-13.4
600x150	M3/H	423	636	847	1059	1272	1482	1695
	dbA				30	35	39	42
	Throw	2.7-4.0	4.3-6.1	5.8-8.2	7.3-10.4	8.5-12.2	10.4-14.3	11.6-16.5
900x150	M3/H	649	974	1299	1624	1948	2273	2598
	dbA				32	37	41	44
	Throw	3.4-4.6	4.6-6.7	6.4-8.8	7.9-11.0	9.4-13.4	11.0-15.5	12.2-17.7
1200x150	M3/H	876	1312	1751	2188	2625	3063	3502
	dbA			27	33	38	42	45
	Throw	3.4-4.9	5.5-7.6	7.6-10.1	8.8-12.5	10.4-14.9	12.2-17.7	14.3-20.1
1500x150	M3/H	1102	1651	2202	2752	3303	3854	4403
	dbA			28	34	39	43	46
	Throw	4.0-5.5	5.8-8.2	7.9-11.0	9.8-13.8	11.6-16.5	13.1-19.2	15.5-22.3
1800x150	M3/H	1326	1989	2652	3315	3978	4641	5304
	dbA			29	35	40	44	47
	Throw	4.0-5.8	6.4-8.8	7.9-11.6	10.7-14.6	11.9-17.4	14.6-20.4	16.5-23.2

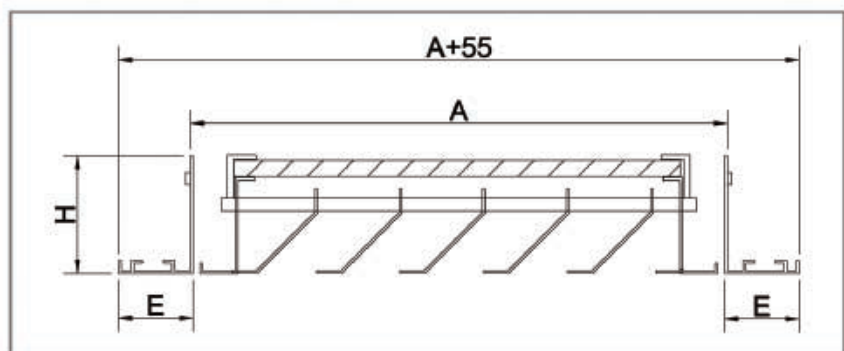
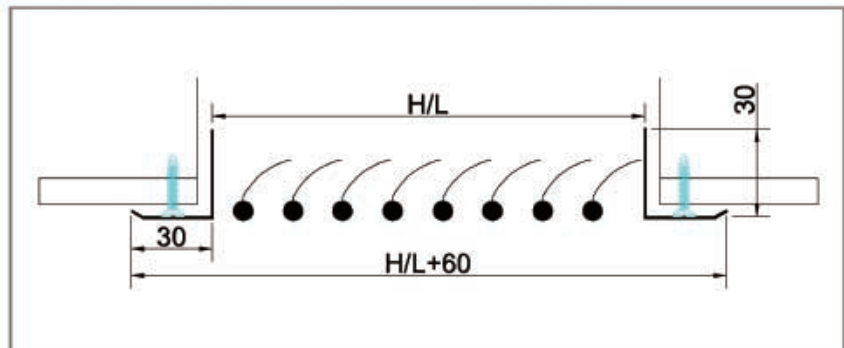
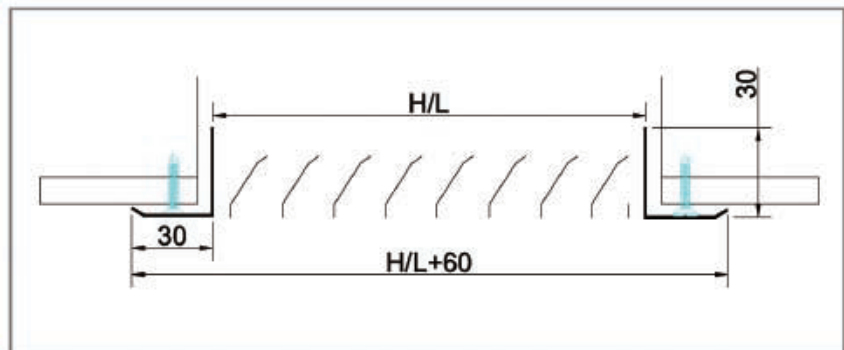

- * They are used as return grille.
- * Blades are fixed at 45°
- * Accessories: Damper, Plenum box.
- * Mounting: Screw mounting is standard, concealed clips mounting as additional
- * Finishing: White powder coating Ral9016, Ral9010, or customized color. Anodized.

Velocity(m/s)	1	1.5	2	2.5	3	3.5	4	5	6	7
Static Pressure	0.1	0.2	0.4	0.6	0.8	1.1	1.5	2.2	3.3	4.6
Size(mm)	Air Flow(M3/H)									
200x100	51	77	102	138	153	179	205	255	306	358
250x100	68	102	136	170	204	238	272	340	408	476
250x150	102	153	204	255	306	357	408	510	612	714
250x200	143	214	286	357	428	500	571	714	857	1000
300x100	88	133	177	221	265	309	354	442	530	619
300x150	126	189	252	315	377	440	503	629	755	881
300x200	177	265	354	443	530	619	707	884	1061	1238
300x300	279	418	558	698	836	976	1115	1395	1673	1952
350x150	146	219	292	366	429	512	585	731	877	1023
350x200	207	311	415	519	622	726	830	1037	1244	1452
400x200	241	362	483	604	724	845	966	1207	1448	1690
400x250	313	469	626	782	938	1095	1251	1565	1877	2190
400x300	381	571	762	952	1142	1333	1523	1904	2285	2666
400x400	524	785	1047	1309	1571	1833	2093	2618	3143	3665
450x200	272	408	544	680	816	952	1088	1360	1632	1904
450x300	432	648	864	1080	1295	1511	1727	2159	2591	3023
450x450	673	1010	1346	1683	2020	2356	2693	3366	4039	4712
500x100	221	332	442	553	663	774	884	1105	1326	1547
500x200	306	459	612	765	918	1071	1224	1530	1836	2142
500x300	483	724	969	1207	1448	1690	1931	2414	2897	3380
600x150	265	398	530	663	796	928	1061	1326	1591	1856
600x300	588	882	1176	1471	1765	2059	2353	2941	3529	4117
600x450	911	1367	1822	2278	2734	3189	3645	4556	5467	6378
600x600	1238	1856	2475	3094	3713	4332	4950	6188	7426	8663
750x200	469	704	938	1173	1408	1642	1877	2346	2815	3284
750x300	728	1091	1455	1819	2183	2547	2910	3638	4366	5093
750x450	1149	1724	2298	2873	3448	4022	4597	5746	6895	8044
750x600	1561	2341	3121	3902	4682	5463	6242	7803	9365	10925
900x300	898	1346	1795	2244	2693	3142	3590	4488	5386	6283
900x450	1387	2081	2774	3468	4162	4855	5549	6936	8323	9710
900x600	1887	2831	3775	4718	5661	6605	7548	9435	11322	13209
900x750	2186	3279	4372	5466	6559	7652	8745	10931	13117	15303
900x900	2485	3728	4971	6214	7456	8699	9942	12427	14912	17400
1200x600	2530	3794	5059	6324	7589	8854	10118	12648	15178	17707
1200x750	2829	4243	5658	7072	8486	9901	11315	14144	16973	19802
1200x900	3584	5375	7167	8959	10751	12543	14334	17918	21502	25085
1200x1200	4743	7115	9486	11568	14229	16601	18972	23715	28458	33201

EGG CRATE GRILLE

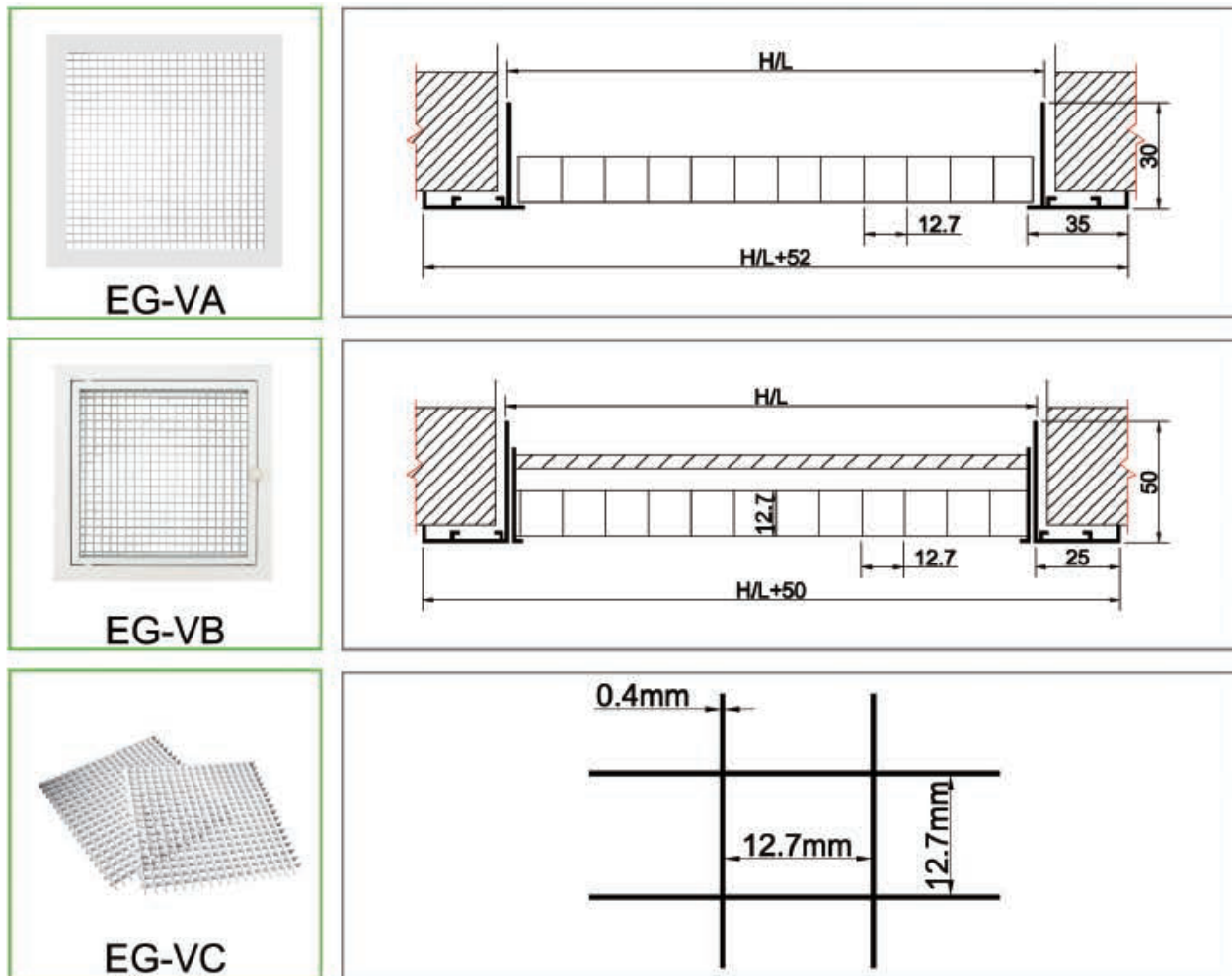

- * They are used as return grille
- * They egg crate size is 12.7x12.7mm, vertical or 45° fixed.
- * The A type is a fixed grille, and the B type is a removable hinged grille with filter.
- * Accessories: Damper, Plenum box.
- * Mounting: screw mounting is standard, and concealed clip fixing is optional.
- * Finishing: White powder coating Ral9016, Ral9010, or customized color. Anodized.

Selection Table:

Standard Size (mm)	Effective Area(m ²)	Air Volume (m ³ /h)
200x200	0.031	300
250x250	0.049	450
300x300	0.076	735
350x350	0.103	900
400x400	0.134	1300
450x450	0.177	1750
500x500	0.212	2050
600x600	0.326	3000
700x700	0.449	4000
800x800	0.590	6000
900x900	0.751	7000

Assumed air velocity is 2.5-2.7m/s

L x H	250x	250	300	350	400	450	500	600	700	800
M3/H										
100	Vel	0.63	0.51	0.43	0.37	0.33	0.29	0.24	0.21	0.18
	P	0.02	0.01	0.01	0.01	0.01	0	0	0	0
	dbA	15	15	15	15	15	15	15	15	15
200	Vel	1.26	1.02	0.86	0.75	0.66	0.59	0.48	0.43	0.36
	P	0.08	0.05	0.04	0.03	0.02	0.02	0.01	0.01	0.01
	dbA	15	15	15	15	15	15	15	15	15
300	Vel	1.89	1.54	1.29	1.12	0.99	0.88	0.73	0.62	0.54
	P	0.18	0.12	0.09	0.06	0.05	0.04	0.03	0.02	0.01
	dbA	19	15	15	15	15	15	15	15	15
400	Vel	2.51	2.05	1.73	1.49	1.31	1.17	0.97	0.82	0.72
	P	0.32	0.21	0.15	0.11	0.09	0.07	0.05	0.03	0.03
	dbA	26	22	18	15	15	15	15	15	15
500	Vel	3.14	2.56	2.16	1.87	1.64	1.47	1.21	1.03	0.90
	P	0.50	0.33	0.24	0.18	0.14	0.11	0.07	0.05	0.04
	dbA	31	27	23	15	17	15	15	15	15
600	Vel	3.77	3.07	2.59	2.24	1.97	1.76	1.45	1.23	1.07
	P	0.73	0.48	0.34	0.26	0.20	0.16	0.11	0.08	0.06
	dbA	35	31	27	24	21	18	15	15	15
700	Vel	4.40	3.58	3.02	2.61	2.30	2.05	1.69	1.44	1.25
	P	0.99	0.65	0.47	0.35	0.27	0.22	0.15	0.11	0.08
	dbA	39	35	31	28	25	22	16	15	15
800	Vel	5.03	4.09	3.45	2.98	2.63	2.35	1.94	1.65	1.43
	P	1.29	0.85	0.61	0.45	0.35	0.28	0.19	0.14	0.10
	dbA	42	38	34	31	28	25	20	15	15
900	Vel	5.66	4.61	3.88	3.36	2.96	2.64	2.18	1.85	1.61
	P	1.63	1.08	0.77	0.57	0.45	0.36	0.24	0.17	0.13
	dbA	45	41	37	34	31	28	22	17	15
1000	Vel	6.29	5.12	4.32	3.73	3.29	2.94	2.42	2.06	1.79
	P	2.20	1.34	0.95	0.71	0.55	0.44	0.30	0.22	0.16
	dbA	48	44	40	37	34	31	25	20	16
1100	Vel		5.63	4.75	4.10	3.61	3.23	2.66	2.26	1.97
	P		16.2	1.15	0.86	0.67	0.53	0.36	0.26	0.20
	dbA		46	43	39	36	33	28	23	18
1200	Vel		6.14	5.18	4.48	3.94	3.52	2.90	2.47	2.15
	P		1.92	1.37	1.02	0.79	0.63	0.43	0.31	0.24
	dbA		49	45	42	38	35	30	25	20

Egg Crate Grille Selection Table

LxH	300x	250	300	350	400	450	500	600	700	800
M3/H										
100	Vel	0.42	0.35	0.30	0.27	0.24	0.20	0.17	0.15	0.13
	P	0.01	0.01	0	0	0	0	0	0	0
	dbA	15	15	15	15	15	15	15	15	15
200	Vel	0.83	0.70	0.61	0.53	0.48	0.39	0.34	0.29	0.26
	P	0.04	0.03	0.02	0.01	0.01	0.01	0.01	0.01	0
	dbA	15	15	15	15	15	15	15	15	15
300	Vel	1.25	1.05	0.91	0.80	0.72	0.59	0.50	0.44	0.39
	P	0.08	0.06	0.04	0.03	0.02	0.01	0.01	0.01	0.01
	dbA	15	15	15	15	15	15	15	15	15
400	Vel	1.67	1.41	1.21	1.07	0.96	0.79	0.67	0.58	0.52
	P	0.14	0.10	0.08	0.06	0.05	0.03	0.02	0.02	0.01
	dbA	17	15	15	15	15	15	15	15	15
500	Vel	2.08	1.76	1.52	1.34	1.19	0.98	0.84	0.73	0.64
	P	0.22	0.16	0.12	0.09	0.07	0.05	0.04	0.03	0.02
	dbA	22	18	15	15	15	15	15	15	15
600	Vel	2.50	2.11	1.82	1.60	1.43	1.18	1.01	0.87	0.77
	P	0.32	0.23	0.17	0.13	0.10	0.07	0.05	0.04	0.03
	dbA	27	23	19	15	15	15	15	15	15
700	Vel	2.92	2.46	2.13	1.87	1.67	1.38	1.17	1.03	0.90
	P	0.43	0.31	0.23	0.18	0.14	0.10	0.07	0.05	0.04
	dbA	30	26	23	19	16	15	15	15	15
800	Vel	3.033	2.81	2.43	2.14	1.91	1.58	1.34	1.17	1.03
	P	0.57	0.40	0.30	0.23	0.19	0.13	0.09	0.07	0.05
	dbA	34	30	26	22	19	15	15	15	15
900	Vel	3.75	3.16	2.73	2.41	2.15	1.77	1.51	1.31	1.16
	P	0.72	0.51	0.38	0.30	0.24	0.16	0.12	0.09	0.07
	dbA	37	33	29	25	22	16	15	15	15
1000	Vel	4.17	3.51	3.04	2.67	2.39	1.97	1.68	1.46	1.29
	P	0.89	0.63	0.47	0.36	0.29	0.20	0.14	0.11	0.08
	dbA	39	35	32	28	25	19	15	15	15
1100	Vel	4.58	3.86	3.35	2.95	2.63	2.17	1.84	1.60	1.42
	P	1.07	0.76	0.57	0.44	0.35	0.24	0.17	0.13	0.10
	dbA	42	38	34	31	27	21	16	15	15
1200	Vel	5.00	4.22	3.64	3.21	2.97	2.36	2.01	1.75	1.55
	P	1.50	1.06	0.80	0.62	0.49	0.33	0.24	0.18	0.14
	dbA	46	42	39	35	32	26	20	15	15

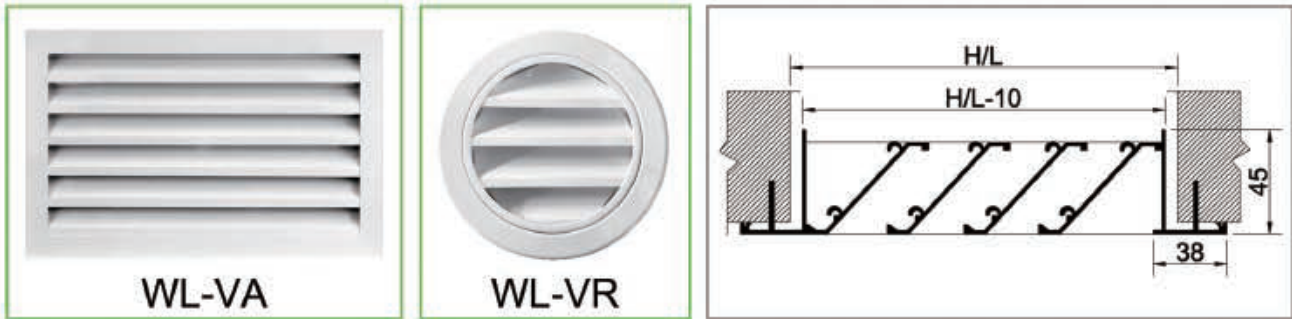

- * They are used as fresh air intake louver usually mounted on the outside wall.
- * Blades are rainproof designed 45°fixed to prevent rain goes into the inside room.
- * Accessories: Damper, Plenum box.
- * Mounting: screw mounting is standard, and concealed clip fixing is optional.
- * Finishing: White powder coating RaI9016, RaI9010, or customized color. Anodized.

Selection Table

WL-VA

		Air Flow M3/H (V=1m/s)										
H \ L	200	200	300	350	400	450	500	600	700	800	900	1000
100	37	48	58	68	78	88	98	118	138	158	178	198
150	58	74	90	106	122	138	154	185	216	247	278	309
200	80	101	123	145	167	189	211	253	295	337	379	421
250	101	129	156	184	212	240	268	321	374	427	480	533
300	122	156	189	223	257	291	325	389	453	517	581	645
350	144	183	222	262	302	342	382	457	532	607	682	757
400	165	210	255	301	347	393	439	526	611	697	783	869
500	208	265	322	379	437	495	553	662	769	877	985	1093
600	251	319	388	457	527	597	667	798	927	1057	1187	1317

Velocity / Pressure Drop (intake)

Velocity	1	2	3	4	5	6	8
P	9.31	1.23	2.76	4.90	7.65	11.0	19.58

WL-VR

Standard size (mm)	Airflow (m3/h) (V=1M/S)
150	40
200	83
250	131
300	191
350	265
400	349

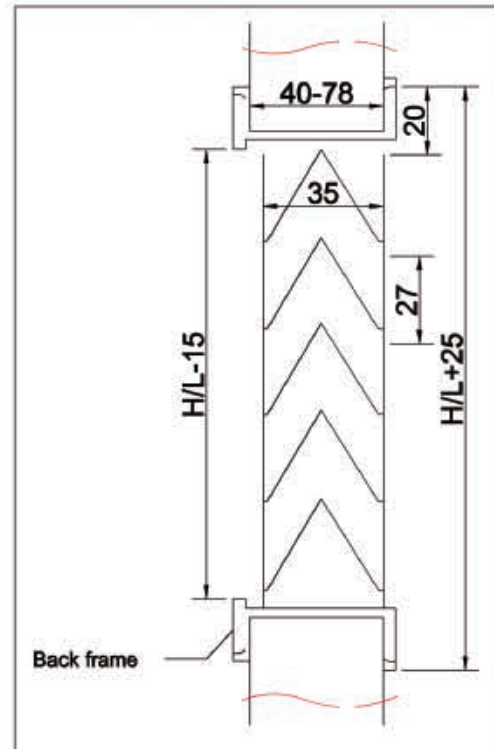

- * They are used as transfer grille on doors or walls for natural air ventilation.
- * Mounting: screw mounting is standard, and concealed clip fixing is optional.
- * Finishing: White powder coating Ral9016, Ral9010, or customized color. Anodized.

Standard Size H/L(mm)	Effective Area(m ²)	Air Volume (m ³ /h)
300x150	0.029	139
500x150	0.050	244
500x250	0.088	429
750x250	0.131	670
750x350	0.183	950
900x300	0.203	1050
900x500	0.338	1750
1000x250	0.188	1000
1000x350	0.263	1360
1000x500	0.400	2070
Assumed velocity is 2.5m/s		



DV-VE
Exhaust Valve



DV-VS
Supply Disc Valve

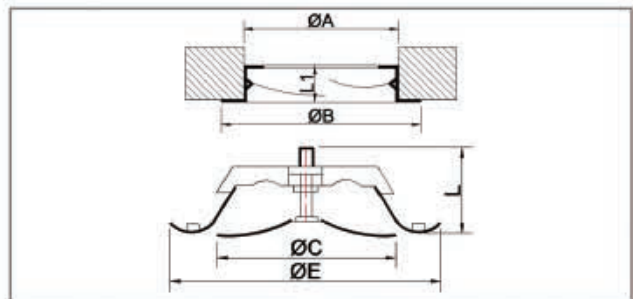
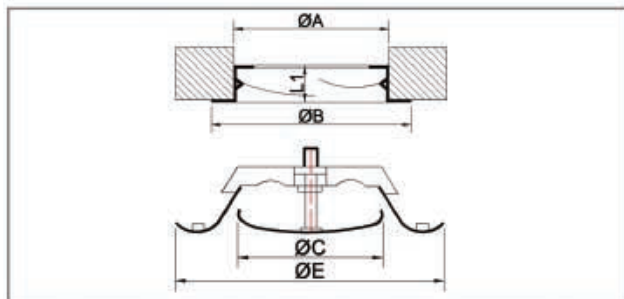

- * They are used mainly in bath rooms for exhaust or supply air.
- * They are suitable for both ventilation and air conditioning.
- * They get a low noise level even at relatively high velocities.
- * They are made of galvanized steel.
- * Mounting: by screw.
- * Finishing: White powder coating Ral9016, Ral9010, or customized color.

Size Table

DV-VE

Size	A	C	E
100	98	75	138
125	123	100	164
150	148	120	202
160	158	130	211
200	198	158	248

DV-VS

Size	A	C	E
100	98	75	138
125	123	100	164
150	148	120	202
160	158	130	211
200	198	158	248

	Nominal Size (mm)					Air Flow, M3/H									
	80	100	125	150/160	200	M3/H	20	40	60	80	100	150	200	300	
Opening Distance (mm)	-9					Pa	90								
						NR	-								
	-6	-9				Pa	45	170							
						NR	-	20							
	-3	-6	-12			Pa	20	80	200	300					
						NR	-	12	25	28					
	0	-3			-20	Pa	10	50	120	200					
						NR	-	-	17	26					
	6		-6			Pa		30	70	120	200				
						NR		-	12	20	28				
	9	6				Pa		20	40	80	130				
						NR		-	-	15	22				
			0		15	Pa		15	30	60	80	200			
						NR		-	-	11	18	30			
		12	6			Pa		10	20	40	60	150			
						NR		-	-	-	13	27			
				0		Pa			15	25	40	90	170		
						NR			-	-	9	21	30		
			12	6		Pa				15	25	60	100	220	
						NR				-	-	15	25	31	
			12	0	Pa					15	30	60	150		
					NR					-	10	18	30		

	Nominal Size (mm)					Air Flow, M3/H									
	80	100	125	150/160	200	M3/H	20	40	60	80	100	150	200	300	
Opening Distance (mm)	3					Pa	90	200							
						NR	30	40							
	0					Pa	50	120	200						
						NR	23	35	42						
	6		-3	-6	-6	Pa	30	75	130	200					
						NR	17	30	37	43					
	3					Pa	20	45	80	130					
						NR	-	25	32	138					
			0	-3	-3	Pa	13	30	60	85	200				
						NR	-	20	28	33	45				
	12	6				Pa	18	22	40	60	150				
						NR	-	15	24	30	42				
				0	0	Pa		15	30	45	100	200			
						NR		-	20	27	39	46			
	12					Pa		12	22	35	80	150			
						NR		-	18	23	35	43			
			6	6		Pa			15	25	60	100			
						NR			-	20	31	38			
			12		6	Pa				13	35	60	130		
						NR				-	23	32	43		
				12	12	Pa				5	20	35	80	150	
						NR				-	17	25	35	48	
					15	Pa					12	22	45	90	
						NR					-	21	32	49	
				20	Pa						13	29	45		
					NR						15	25	33		



DV-VP

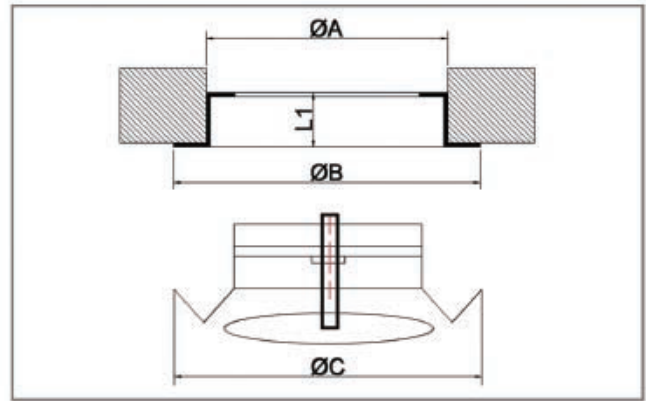

Standard Size(mm)
100
125
150
200

Features:

- * Made of pp.
- * Adjust the air volume by rotating the valve disc .In plus or minus direction.



DV-VA

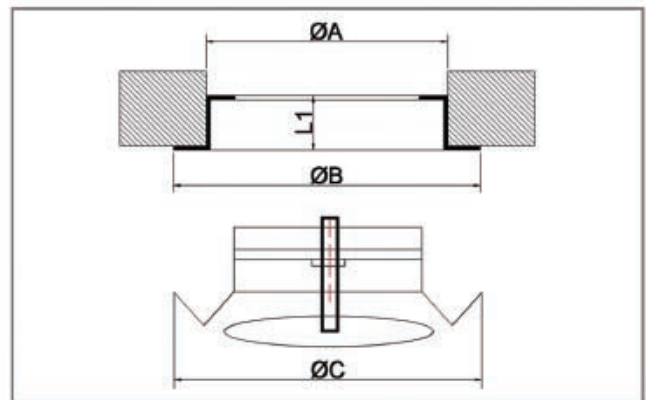

Standard Size(mm)
75
100
125
150
200

Features:

- * Made of ABS.
- * Adjust the air volume by rotating the valve disc .In plus or minus direction.

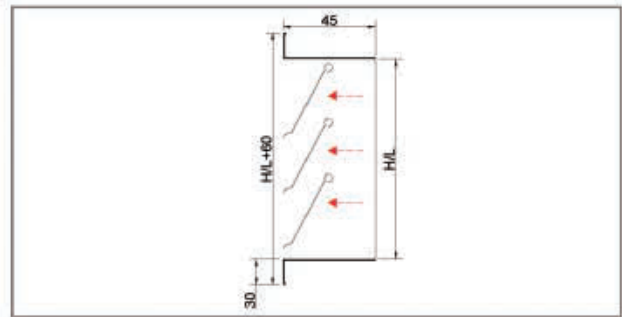

- * They are used for air extraction and automatic closing of duct when the fan is switched off.
- * They consist of a frame and movable plates mounted horizontally one above the other.
- * They are installed only vertically with blades downwards.
- * Finishing: White powder coating Ral9016, Ral9010, or customized color. Anodized color.

Selection table

1. Effective Area (m2)

H (mm)	L (mm)									
	150	200	259	300	350	400	450	500	550	600
150	0.018	0.024	0.030	0.037	0.043	0.049	0.063	0.073	0.085	0.098
200	0.024	0.032	0.041	0.049	0.058	0.067	0.084	0.098	0.115	0.132
250	0.030	0.041	0.051	0.062	0.073	0.084	0.105	0.124	0.145	0.167
300	0.037	0.050	0.063	0.077	0.090	0.103	0.130	0.152	0.179	0.205
350	0.043	0.058	0.074	0.089	0.105	0.121	0.152	0.178	0.209	0.240
350	0.049	0.067	0.085	0.102	0.120	0.138	0.173	0.203	0.239	0.274
350	0.055	0.067	0.095	0.115	0.135	0.155	0.195	0.229	0.269	0.309
350	0.062	0.085	0.107	0.130	0.152	0.175	0.219	0.257	0.302	0.347
350	0.068	0.093	0.118	0.142	0.167	0.192	0.241	0.283	0.332	0.382
350	0.074	0.101	0.128	0.155	0.182	0.209	0.263	0.308	0.362	0.416

2. Air Volume (m3/h) with 3m/s velocity

H (mm)	L (mm)									
	150	200	259	300	350	400	450	500	550	600
150	194	259	324	400	464	529	670	788	918	1058
200	259	346	443	529	626	724	907	1058	1242	1426
250	324	443	551	670	788	907	1134	1339	1566	1804
300	400	540	680	832	972	1112	1404	1642	1933	2214
350	464	626	799	961	1134	1307	1642	1922	2257	2592
400	529	724	918	1102	1296	1490	1868	2192	2581	2959
450	594	810	1026	1242	1458	1674	2106	2473	2905	3337
500	670	918	1156	1404	1642	1890	2365	2776	3262	3748
550	734	1004	1274	1534	1804	2074	2603	3056	3586	4126
550	799	1091	1382	1674	1966	2257	2840	3326	3910	4493

BALL WEATHER LOUVER



BWL-VA

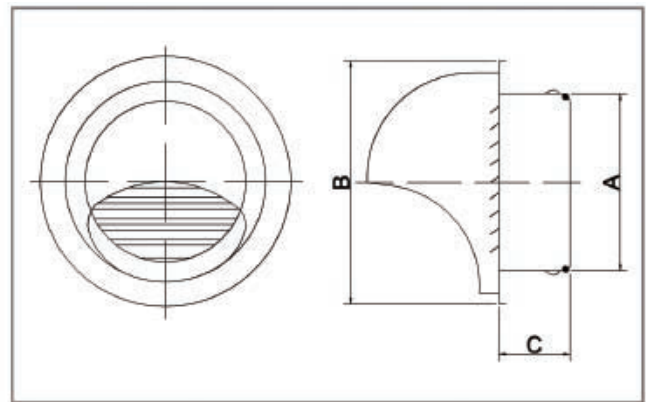

Size(mm)
100
125
150
200

Features:

- * Made of high quality stainless steel.
- * With insect wire mesh



BWL-VB

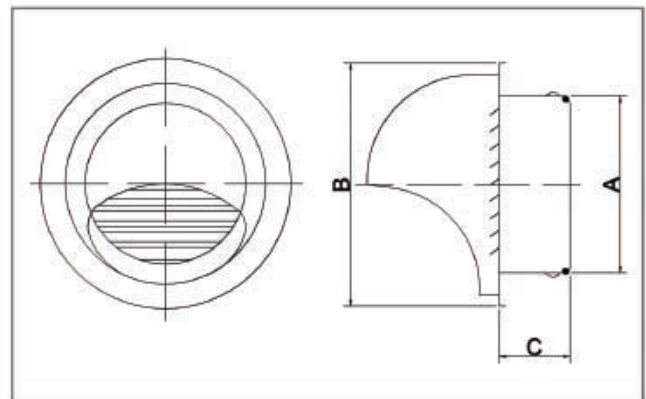

Size(mm)
100
125
150
200

Features:

- * Made of high quality aluminium sheet.
- * Color RAL9010.RAL9016

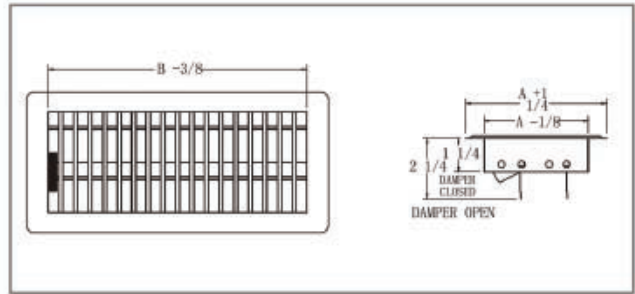
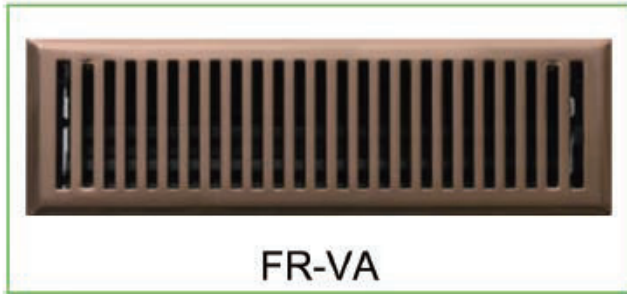

Features:

- * Made of iron sheet.
- * Color Nickel, rRed Copper, Black, Antique, Bronze, White.

Size(inch)		
2x10	2x12	2x14
4x10	4x12	4x14
6x10	6x12	6x14

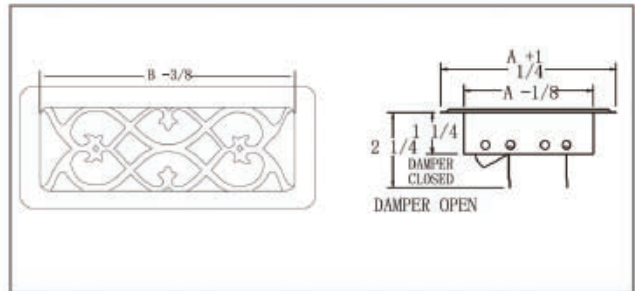
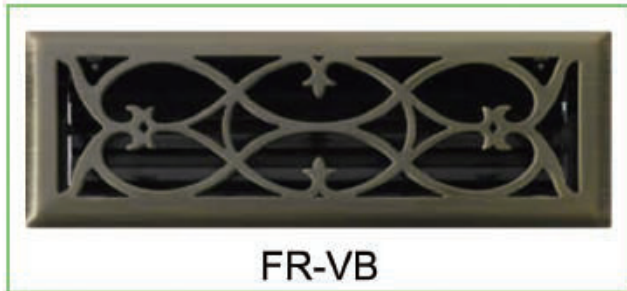

Features:

- * Made of iron sheet.
- * Color Nickel, rRed Copper, Black, Antique, Bronze, White.

Size(inch)		
2x10	2x12	2x14
4x10	4x12	4x14
6x10	6x12	6x14

Opposed Blades Damper

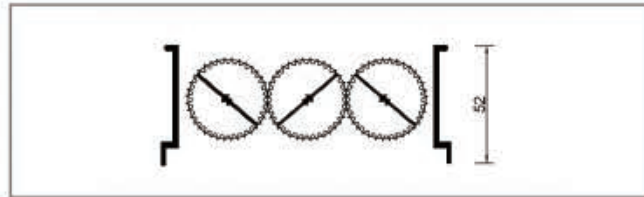

Features:

- * Made of high quality extruded aluminium profile.
- * used as damper for square diffuser.
- * Accurate gear wheel control.

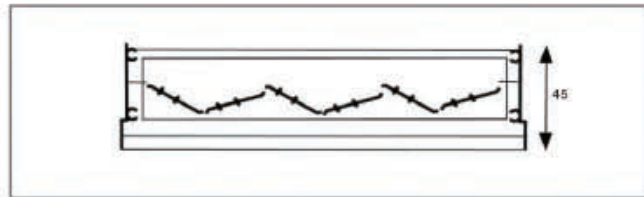
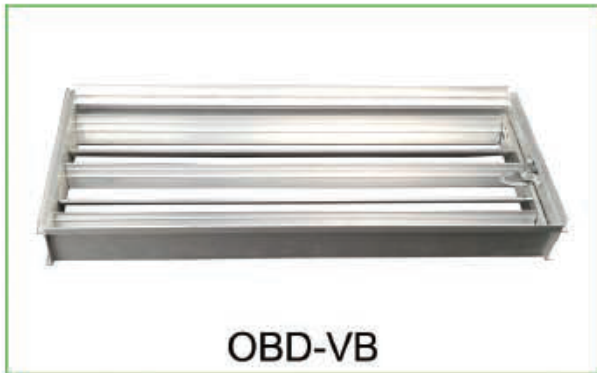

Features:

- * Made of high quality extruded aluminium profile.
- * Used as damper for grilles.
- * Mechanical control operated by screw driver.

Butterfly damper



Features:

- * Made of high quality GI sheet.
- * Damper for round diffusers.
- * Standard sizes: 150, 200, 250, 300, 350, 400, 450, 500

Slide Damper



Features:

- * Made of high quality GI sheet.
- * Damper for round diffusers.
- * Standard sizes: 150, 200, 250, 300, 350, 400, 450, 500



VCD-VA

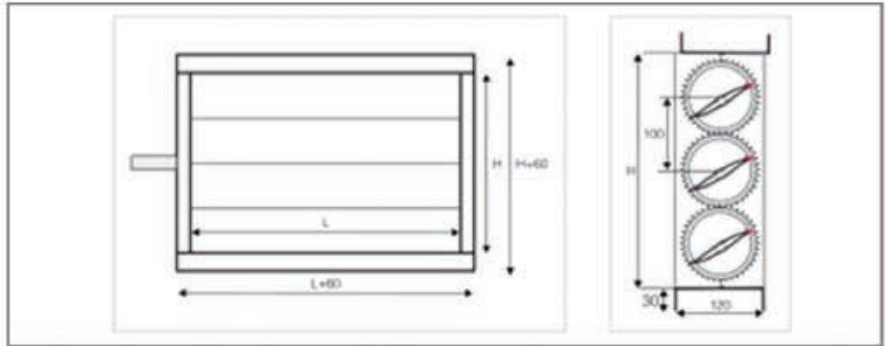

- * They are made of extruded aluminum profile.
- * They are used to adjust air volume on duct systems.
- * Control: manually or by electrical actuator.
- * Sizes are according to customers' needs.
- * Color: Anodized.



VCD-VB

Standard sizes	D1	D2
100	98	104
125	123	129
150	148	154
160	158	164
200	198	204
250	248	254
315	313	319

- * They are used to adjust air volume on round duct systems
- * They are made of galvanized steel sheet material.
- * Control: manually or by electrical actuator.



Back Draught Damper

Standard sizes	D1	D2
100	98	104
125	123	129
150	148	154
160	158	164
200	198	204
250	248	254
315	313	319

Features

- * Frame made of high quality GI sheet 0.6mm.and blades made of aluminium sheet 0.3mm.
- * It's used to break the supply and return air.after turn off the air equipments.

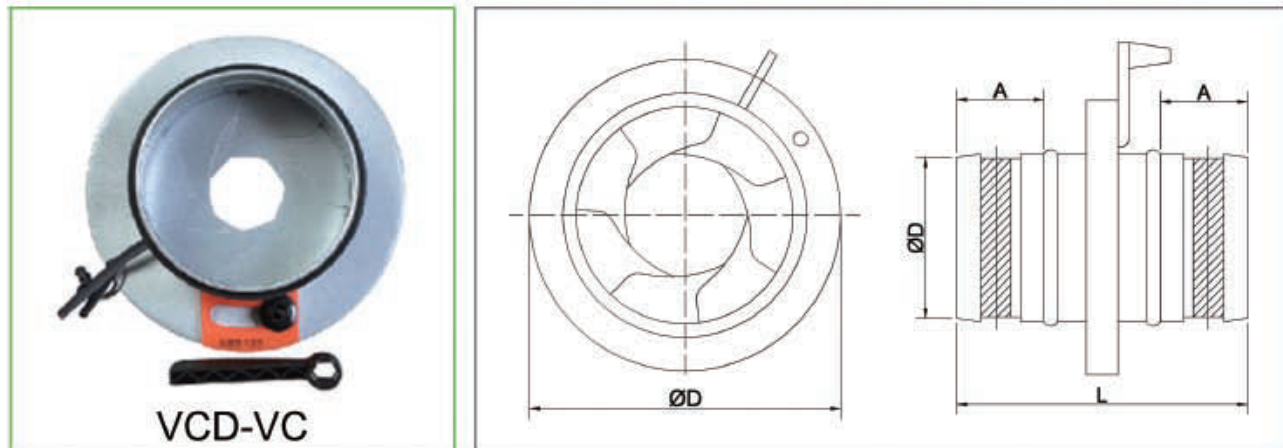

- * They are ideal air flow regulator and measuring device for circular ducts.
- * The diaphragm valve ensures a perfect accordance between the diameter indication on the handle and the opening of the valve.
- * They provides a 100% free area when in fully open position.
- * They are made of galvanized steel sheet, with EPDM seal rings.
- * They are with selection graph, mentioning the air volume and pressure level at different opening.
- * They are available in range from 80mm to 800mm

Size Table:

Size	d(mm)	D(mm)	L(mm)	A(mm)	Material Thickness(mm)
80	79	125	115	33	0.6
100	99	165	115	27	0.6
125	124	188	115	27	0.6
150	149	230	115	27	0.6
160	159	230	115	27	0.6
200	199	285	120	27	0.6
250	249	335	135	33	0.6
300	299	405	140	33	0.6
315	314	405	140	33	0.6
400	398	525	150	46	1.0
500	498	655	150	46	1.0
630	628	815	155	46	1.0
800	798	1015	285	110	1.0



Diameter		Length
mm	Inch	m/pcs
100	4	10
125	5	10
150	6	10
200	8	10
250	10	10
300	12	10
350	14	10
400	16	10

<p>NON - INSULATED</p>	<p>Description: Non-insulated aluminum flexible ducts are produced from two layer aluminum strengthened with high tension hard steel spring wire.</p> <p>Standard Length: 10 Meters</p> <p>Packaging: Individual Carton Boxes</p> <p>Fire Resistance: Difficult-Flammability</p> <p>Diameter Range: 100~610mm</p> <p>Temperature Range: -30~+140°C</p> <p>Max Air Velocity: 30m/s</p> <p>Max Working Pressure: 2500Pa</p>
<p>WITH INSULATION</p>	<p>Description: Insulated flexible duct made of a thermal flex inner wall, supporting a 25 thickness 18kg/m3 fiberglass insulation, sheathed in a reinforced aluminum/polyester laminated jacket acting as a vapor barrier</p> <p>Standard Length: 10 Meters</p> <p>Packaging: Individual Carton Boxes</p> <p>Fire Resistance: Difficult-Flammability</p> <p>Diameter Range: 100~610mm</p> <p>Temperature Range: -30~+140°C</p> <p>Max Air Velocity: 30m/s</p> <p>Max Working Pressure: 2500Pa</p> <p>Density: 18kg/m3</p> <p>Thickness: 25~50mm</p> <p>Conductivity Factor: 0.034W/mK</p>

